



MFPA Leipzig GmbH

Testing, Inspection and Certification Authority for
Construction Products and Construction Types

Center for Innovation and Calculation

Dr.-Ing. Susanne Reichel

Work Group - FEM

Dr.-Ing. Susanne Reichel

Telefon +49 (0) 341-6582-106

s.reichel@mfpa-leipzig.de

Advisory Opinion No. GS 6.1/20-004-3

22.06.2020

Translation of the original German document GS 6.1/20-004-3

Object:

Assessment of the load bearing behaviour of bonded anchors VMZ-A, VMZ-IG and VMZ dynamic made of high corrosion resistant steel with Injection System VMZ under tensile loading and one-sided fire loading according to the ZTV-ING-curve - abbreviated version

Client:

Metall-Kunststoff-Technik GmbH & Co.KG

Auf dem Immel 2

D-67685 Weilerbach

Prepared by:

Dr.-Ing. Susanne Reichel

This document covers 16 pages, including 0 appendices.

This document may only be reproduced in its unabbreviated form. All publication, even in excerpts, requires the prior written permission of MFPA Leipzig GmbH. The legal binding form is the written German form with the original signatures and original stamp of the authorized signatory / signatories. General terms and conditions of MFPA Leipzig GmbH are valid.

Gesellschaft für Materialforschung und Prüfungsanstalt für das Bauwesen Leipzig mbH (MFPA Leipzig GmbH)

Head Office:	Hans-Weigel-Str. 2b – 04319 Leipzig/Germany
Managing Director:	Dr.-Ing. habil. Jörg Schmidt
Comm. Register:	Local Court Leipzig HRB 17719
VAT-ID:	DE 813200649
Tel.:	+49 (0) 341-6582-0
Fax:	+49 (0) 341-6582-135



Contents

I	Objective and request	3
II	Description of the construction	4
III	References	6
1	Utilized guidelines, rules and standards	6
2	Reference documents	6
2.1	ETAs and Verifications of applicability	7
2.2	Assessment and test reports	7
IV	Assessment of the performance	8
1	Design concept	8
2	Pull-out failure	9
3	Steel failure	11
4	Concrete cone failure	13
V	Special notes	15



I Objective and request

MFPA Leipzig GmbH was ordered by MKT GmbH & Co.KG to assess the load bearing behaviour of bonded anchors VMZ-A, VMZ-IG and VMZ dynamic made of high corrosion resistant steel with Injection System VMZ or VMZ Express under tensile loading and one-sided fire loading according to the ZTV-ING-curve according to [N1]. The assessment bases on results of fire tests and numerical simulations and includes the failure modes "steel failure", "pull-out failure" and "concrete cone failure".

The document at hand summarizes the design concept in case of fire and the corresponding characteristic tensile load bearing capacities. For the detailed derivation of the values, please see [G1].

II Description of the construction

The MKT Injection System VMZ is a bonded anchor for use in concrete constructions, consisting of a mortar cartridge VMZ or VMZ Express, an anchor rod with cones as well as a hexagon nut and a washer. Concerning the anchor rod, the variants "anchor rod" VMZ-A and "internal threaded rod" VMZ-IG may be distinguished according to [P1]. Furthermore, a bonded anchor for dynamic loading is approved in [P2] with the Injection System "VMZ dynamic". Figures 1 to 3 show principle pictures of the anchor geometries.

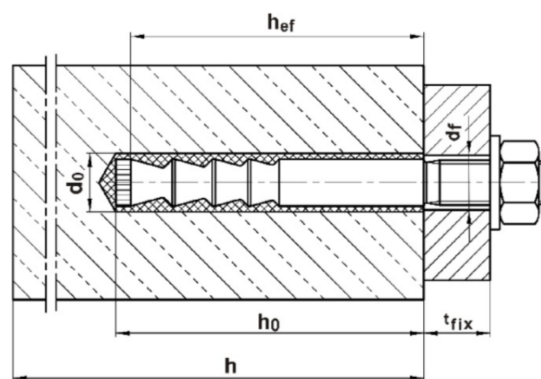

Figure 1: Injection System VMZ with anchor rod VMZ-A: On-site geometry, from [P1]

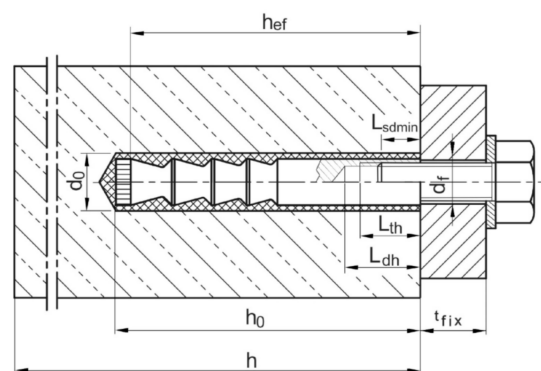

Figure 2: Injection System VMZ with anchor rod VMZ-IG: On-site geometry, from [P1]

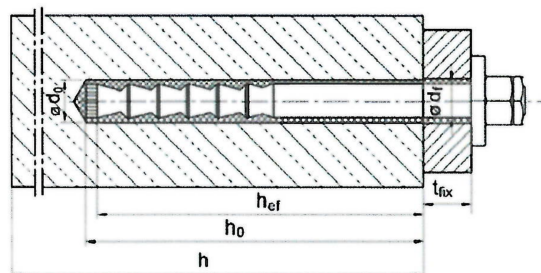

Figure 3: Injection System VMZ with anchor rod VMZ dynamic: On-site geometry, from [P2]

Load transmission mainly occurs due to the mechanical tothing of the cones within the injection mortar as well as, in addition, a combination of cohesion and friction forces in the anchorage. The bonded anchors are approved for the use under static and quasi-static loading (in case of VMZ dynamic also dynamic loading) in reinforced and unreinforced normal concrete of the strength class of at least C20/25 and at most C50/60 according to [N2]. The required diameter and depth of the drill hole as well as the minimum component thickness are specified for each anchor in [P1, P2]. In the course of installation of the bonded anchors, the manufacturers' instructions have to be obeyed (see [P1, P2]). According to [P1, P2], the anchor rods of the Injection System VMZ are available in three different materials:

- galvanized steel according to [N3],
- stainless steel A4 according to [N4],
- high corrosion resistant steel according to [N4].

In the framework of the assessment at hand, exclusively anchor rods made of high corrosion resistant steel are dealt with. The size 170 M20 is omitted for VMZ dynamic HCR.

For a detailed product description and further information with respect to the scope of application, please see [P1, P2].

III References

1 Utilized guidelines, rules and standards

The analyses are based on the following guidelines, rules and standards:

- [N1] Zusätzliche Technische Vertragsbedingungen und Richtlinien für Ingenieurbauten, ZTV-ING: Teil 5, Tunnelbau – Bundesanstalt für Straßenwesen, Stand: 2018/01
- [N2] DIN EN 206:2017-01: Concrete - Specification, performance, production and conformity; German version EN 206:2013+A1:2016
- [N3] DIN EN 10087:1999-01: Free-cutting steels - Technical delivery conditions for semi-finished products, hot-rolled bars and rods; German version EN 10087:1998
- [N4] DIN EN 10088-2:2014-12: Stainless steels - Part 2: Technical delivery conditions for sheet/plate and strip of corrosion resisting steels for general purposes; German version EN 10088-2:2014
- [N5] DIN EN 1992-4:2019-04: Eurocode 2 - Design of concrete structures - Part 4: Design of fastenings for use in concrete; German version EN 1992-4:2018
- [N6] ETAG 001; Guideline for European Technical Approval of metal anchors for use in concrete; April 2013
- [N7] TR 020: Evaluation of Anchorages in Concrete concerning Resistance to Fire; 05/2004
- [N8] EAD 330232-00-0601: Mechanical fasteners for use in concrete; 10/2016
- [N9] DIN EN 1992-1-2:2010-12: Eurocode 2: Design of concrete structures - Part 1-2: General rules - Structural fire design; German version EN 1992-1-2:2004 + AC:2008

2 Reference documents

The analyses are based on the following additional documents:

2.1 ETAs and Verifications of applicability

- [P1] ETA-04/0092: MKT Injection System VMZ, Torque controlled bonded anchor with anchor rod VMZ-A and internal threaded rod VMZ-IG for use in concrete – Deutsches Institut für Bautechnik, 13.04.2017
- [P2] ETA-17/0194: Injection System VMZ dynamic, Post-installed fasteners in concrete under fatigue cyclic loading – Deutsches Institut für Bautechnik, 31.05.2018

2.2 Assessment and test reports

- [G1] Gutachterliche Stellungnahme Nr. GS 6.1/20-004-1: Bewertung des Tragverhaltens eingeklebter stählerner Verbunddübel VMZ-A, VMZ-IG und VMZ dynamic aus hochkorrosionsbeständigem Stahl mit Injektionssystem VMZ unter zentrischem Zug und einseitiger Brandbeanspruchung mit der ZTV-ING-Kurve – MFPA Leipzig GmbH; 17.06.2020

IV Assessment of the performance

1 Design concept

The characteristic load bearing capacity of a bonded anchor in case of fire has to be determined as the minimum value of the load bearing capacities for the failure modes steel failure, pull-out failure and concrete cone failure

$$N_{Rk,fi} = \min [N_{Rk,p,fi}, N_{Rk,s,fi}, N_{Rk,c,fi}]. \quad (1)$$

In case of the failure modes pull-out failure and steel failure, the values specified in Tables 1 to 3 and 4 to 6, respectively, may directly be inserted into equation (1).

With respect to the failure mode concrete cone failure, Tables 7 to 9 show the load bearing capacities $N_{Rk,c,fi}^0$ for a single anchor. The determination of $N_{Rk,c,fi}$ as input quantity for equation (1) is done depending on the specific construction according to [N5], chapter 7.2.1.4 and Appendix D.4.2.2 under consideration of [P1]. Diverging from the instructions of [N5], chapter 7.2.1.4, the cube compressive strength of the surrounding concrete has to be used for f_{ck} , since $k_{cr,N}$ and $k_{ucr,N}$ (see [P1, P2]) have been determined basing on [N6].

2 Pull-out failure

The following tables show the characteristic tensile load bearing capacities $N_{Rk,p,fi}$ of the different bonded anchors for pull-out failure.

		$N_{Rk,p,fi}$ [kN]
A1-HCR	40 M8	0,00
A2-HCR	50 M8	0,00
A3-HCR	60 M10	0,22
A4-HCR	75 M10	1,15
A5-HCR	75 M12	1,49
A6-HCR	70 M12	0,88
A7-HCR	80 M12	1,94
A8-HCR	95 M12	3,99
A9-HCR	100 M12	5,27
A10-HCR	110 M12	6,93
A11-HCR	125 M12	9,08
A12-HCR	90 M16	3,85
A13-HCR	105 M16	7,21
A14-HCR	125 M16	12,91
A15-HCR	145 M16	17,21
A16-HCR	160 M16	22,46
A17-HCR	115 M20	9,75
A18-HCR	170 M20	31,48
A19-HCR	190 M20	37,74
A20-HCR	170 M24	39,76
A21-HCR	200 M24	52,06
A22-HCR	225 M24	61,92

Table 1: Injection System VMZ with anchor rod VMZ-A of high corrosion resistant steel: Characteristic tensile load bearing capacity $N_{Rk,p,fi}$ [kN] for pull-out failure

		$N_{Rk,p,fi}$ [kN]
IG1-HCR	IG 40 M6	0,00
IG2-HCR	IG 50 M6	0,00
IG3-HCR	IG 60 M8	0,22
IG4-HCR	IG 75 M8	1,49
IG5-HCR	IG 70 M10	0,88
IG6-HCR	IG 80 M10	1,94
IG7-HCR	IG 90 M12	3,85
IG8-HCR	IG 105 M12	7,21
IG9-HCR	IG 125 M12	12,91
IG10-HCR	IG 115 M16	9,75
IG11-HCR	IG 170 M16	31,48
IG12-HCR	IG 170 M20	39,76

Table 2: Injection System VMZ with anchor rod VMZ-IG of high corrosion resistant steel: Characteristic tensile load bearing capacity $N_{Rk,p,fi}$ [kN] for pull-out failure

		$N_{Rk,p,fi}$ [kN]
D1-A4	100 M12 dyn	5,32
D2-A4	125 M16 dyn	13,34

Table 3: Injection System VMZ with anchor rod VMZ dynamic of high corrosion resistant steel: Characteristic tensile load bearing capacity $N_{Rk,p,fi}$ [kN] for pull-out failure

3 Steel failure

The following tables show the characteristic tensile load bearing capacities $N_{Rk,s,fi}$ of the different bonded anchors for steel failure.

		$N_{Rk,s,fi}$ [kN]
A1-HCR	40 M8	*
A2-HCR	50 M8	*
A3-HCR	60 M10	1,08
A4-HCR	75 M10	1,08
A5-HCR	75 M12	2,25
A6-HCR	70 M12	2,50
A7-HCR	80 M12	2,50
A8-HCR	95 M12	2,50
A9-HCR	100 M12	2,50
A10-HCR	110 M12	2,50
A11-HCR	125 M12	2,50
A12-HCR	90 M16	4,10
A13-HCR	105 M16	4,10
A14-HCR	125 M16	4,10
A15-HCR	145 M16	4,10
A16-HCR	160 M16	4,10
A17-HCR	115 M20	5,04
A18-HCR	170 M20	5,60
A19-HCR	190 M20	5,60
A20-HCR	170 M24	8,07
A21-HCR	200 M24	8,07
A22-HCR	225 M24	8,07

Table 4: Injection System VMZ with anchor rod VMZ-A of high corrosion resistant steel: Characteristic tensile load bearing capacity $N_{Rk,s,fi}$ [kN] for steel failure (* steel failure not decisive)

		$N_{Rk,s,fi}$ [kN]
IG1-HCR	IG 40 M6	*
IG2-HCR	IG 50 M6	*
IG3-HCR	IG 60 M8	0,324
IG4-HCR	IG 75 M8	0,324
IG5-HCR	IG 70 M10	0,75
IG6-HCR	IG 80 M10	0,75
IG7-HCR	IG 90 M12	1,23
IG8-HCR	IG 105 M12	1,23
IG9-HCR	IG 125 M12	1,23
IG10-HCR	IG 115 M16	1,51
IG11-HCR	IG 170 M16	1,68
IG12-HCR	IG 170 M20	2,42

Table 5: Injection System VMZ with anchor rod VMZ-IG of high corrosion resistant steel: Characteristic tensile load bearing capacity $N_{Rk,s,fi}$ [kN] for steel failure (* steel failure not decisive)

		$N_{Rk,s,fi}$ [kN]
D1-HCR	100 M12 dyn	2,50
D2-HCR	125 M16 dyn	4,10

Table 6: Injection System VMZ with anchor rod VMZ dynamic of high corrosion resistant steel: Characteristic tensile load bearing capacity $N_{Rk,s,fi}$ [kN] for steel failure

4 Concrete cone failure

The following tables show the characteristic tensile load bearing capacities $N_{Rk,c,fi}^0$ of the different bonded anchors for concrete cone failure of one single anchor.

		$N_{Rk,c,fi}^0$ [kN]
A1	40 M8	1,46
A2	50 M8	2,55
A3	60 M10	4,02
A4	75 M10	7,01
A5	75 M12	7,01
A6	70 M12	5,90
A7	80 M12	8,24
A8	95 M12	12,67
A9	100 M12	14,40
A10	110 M12	18,27
A11	125 M12	25,16
A12	90 M16	11,07
A13	105 M16	16,27
A14	125 M16	25,16
A15	145 M16	36,46
A16	160 M16	46,63
A17	115 M20	20,42
A18	170 M20	54,26
A19	190 M20	71,65
A20	170 M24	54,26
A21	200 M24	81,46
A22	225 M24	109,35

Table 7: Injection System VMZ with anchor rod VMZ-A: Characteristic tensile load bearing capacity $N_{Rk,c,fi}^0$ [kN] of a single anchor for concrete cone failure

		$N_{Rk,c,fi}^0$ [kN]
IG1	IG 40 M6	1,46
IG2	IG 50 M6	2,55
IG3	IG 60 M8	4,02
IG4	IG 75 M8	7,01
IG5	IG 70 M10	5,90
IG6	IG 80 M10	8,24
IG7	IG 90 M12	11,07
IG8	IG 105 M12	16,27
IG9	IG 125 M12	25,16
IG10	IG 115 M16	20,42
IG11	IG 170 M16	54,26
IG12	IG 170 M20	54,26

Table 8: Injection System VMZ with anchor rod VMZ-IG: Characteristic tensile load bearing capacity $N_{Rk,c,fi}^0$ [kN] of a single anchor for concrete cone failure

		$N_{Rk,c,fi}^0$ [kN]
D1	100 M12 dyn	14,40
D2	125 M16 dyn	25,16

Table 9: Injection System VMZ with anchor rod VMZ dynamic: Characteristic tensile load bearing capacity $N_{Rk,c,fi}^0$ [kN] of a single anchor for concrete cone failure

V Special notes

The assessment at hand is valid for bonded anchors VMZ-A, VMZ-IG and VMZ dynamic with Injection System VMZ or VMZ Express manufactured by MKT GmbH & Co.KG which are installed according to the manufacturers' instructions in [P1, P2]. The mechanical loading may not exceed the load bearing capacity in ambient climate specified in [P1, P2].

The load bearing capacities specified in the framework of the document at hand are determined for one-sided fire loading according to the ZTV-ING-curve. According to [N7], the values may also be used for multilateral fire loading when the edge distance of the anchor is $c \geq 300\text{mm}$ and $c \geq 2 \cdot h_{ef}$.

The load bearing capacities specified in the framework of the document at hand are determined for central tensile loading in the anchors longitudinal direction. According to [N8], the values may be transferred to tensile loading perpendicular and diagonal to the axis of the anchor on the safe side.

For internal threaded rods VMZ-IG screws, threaded rods and nuts of the strength class ≥ 70 have to be utilized.

The assessment at hand is valid for constructions of reinforced or unreinforced normal concrete of the strength class $\geq C20/25$ and $\leq C50/60$ according to [N2], which exhibit at least the same fire resistance class as the utilized anchors. The design of the concrete construction has to be carried out according to [N9].

The load bearing capacities specified in the framework of the document at hand are determined assuming that no explosive concrete spalling occurs and are only valid under this condition. Evidence on the prevention of explosive concrete spalling is given in [N9], chapter 4.5.

Verfasser: **MFPA Leipzig GmbH - Center for Innovation and Calculation**
Hans-Weigel-Str 2b • 04319 Leipzig, Germany • +49 (0) 341-6582-106



Programm: Proj.-Nr.: GS 6.1/20-004-3

Bauwerk: Advisory Opinion

ASB-Nr.:

Date: 22.06.2020

This document does not replace a certificate of constancy of performance or suitability according to national and European building codes.

Leipzig, 22.06.2020

A handwritten signature in blue ink that reads 'S. Reichel'.

Dr.-Ing. S. Reichel
Head of Business Division

Bauteil: V Special notes

Archiv-Nr.:

Block: Page: 16

Vorgang: