

Deutsches Institut für Bautechnik

Anstalt des öffentlichen Rechts

Kolonnenstr. 30 L
10829 Berlin
Germany

Tel.: +49(0)30 787 30 0
Fax: +49(0)30 787 30 320
E-mail: dibt@dibt.de
Internet: www.dibt.de

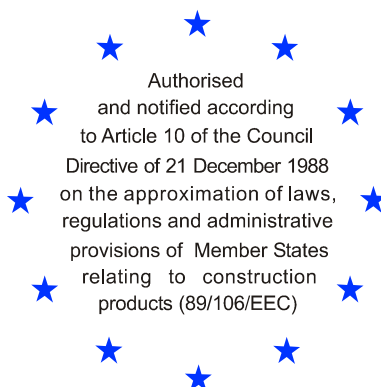

DIBt

Mitglied der EOTA
Member of EOTA

European Technical Approval ETA-07/0299

English translation prepared by DIBt - Original version in German language

Handelsbezeichnung
Trade name

MKT Injektionssystem VME
MKT Injection System VME

Zulassungsinhaber
Holder of approval

MKT
Metall-Kunststoff-Technik GmbH & Co. KG
Auf dem Immel 2
67685 Weilerbach
DEUTSCHLAND

Zulassungsgegenstand
und Verwendungszweck
*Generic type and use
of construction product*

Nachträglich eingemörtelter Bewehrungsanschluss mit dem
MKT Injektionssystem VME
Post-installed rebar connection with MKT Injection Adhesive VME

Geltungsdauer: vom
Validity: from
bis
to

4 July 2008
4 July 2013

Herstellwerk
Manufacturing plant

MKT
Metall-Kunststoff-Technik GmbH & Co. KG
Auf dem Immel 2
67685 Weilerbach
DEUTSCHLAND

Diese Zulassung umfasst
This Approval contains

19 Seiten einschließlich 9 Anhänge
19 pages including 9 annexes



Europäische Organisation für Technische Zulassungen
European Organisation for Technical Approvals

I LEGAL BASES AND GENERAL CONDITIONS

- 1 This European technical approval is issued by Deutsches Institut für Bautechnik in accordance with:
 - Council Directive 89/106/EEC of 21 December 1988 on the approximation of laws, regulations and administrative provisions of Member States relating to construction products¹, modified by Council Directive 93/68/EEC² and Regulation (EC) N° 1882/2003 of the European Parliament and of the Council³;
 - Gesetz über das In-Verkehr-Bringen von und den freien Warenverkehr mit Bauprodukten zur Umsetzung der Richtlinie 89/106/EWG des Rates vom 21. Dezember 1988 zur Angleichung der Rechts- und Verwaltungsvorschriften der Mitgliedstaaten über Bauprodukte und anderer Rechtsakte der Europäischen Gemeinschaften (Bauproduktengesetz - BauPG) vom 28. April 1998⁴, zuletzt geändert durch Gesetz vom 06.01.2004⁵;
 - Common Procedural Rules for Requesting, Preparing and the Granting of European technical approvals set out in the Annex to Commission Decision 94/23/EC⁶;
 - Guideline for European technical approval of "Metal anchors for use in concrete - Part 5: Bonded anchors", ETAG 001-05.
- 2 Deutsches Institut für Bautechnik is authorized to check whether the provisions of this European technical approval are met. Checking may take place in the manufacturing plant. Nevertheless, the responsibility for the conformity of the products to the European technical approval and for their fitness for the intended use remains with the holder of the European technical approval.
- 3 This European technical approval is not to be transferred to manufacturers or agents of manufacturers other than those indicated on page 1, or manufacturing plants other than those indicated on page 1 of this European technical approval.
- 4 This European technical approval may be withdrawn by Deutsches Institut für Bautechnik, in particular pursuant to information by the Commission according to Article 5(1) of Council Directive 89/106/EEC.
- 5 Reproduction of this European technical approval including transmission by electronic means shall be in full. However, partial reproduction can be made with the written consent of Deutsches Institut für Bautechnik. In this case partial reproduction has to be designated as such. Texts and drawings of advertising brochures shall not contradict or misuse the European technical approval.
- 6 The European technical approval is issued by the approval body in its official language. This version corresponds fully to the version circulated within EOTA. Translations into other languages have to be designated as such.

1 Official Journal of the European Communities L 40, 11.02.1989, p. 12
2 Official Journal of the European Communities L 220, 30.08.1993, p. 1
3 Official Journal of the European Union L 284, 31.10.2003, p. 25
4 Bundesgesetzblatt I, p. 812
5 Bundesgesetzblatt I, p.2, 15
6 Official Journal of the European Communities L 17, 20.01.1994, p. 34

II SPECIFIC CONDITIONS OF THE EUROPEAN TECHNICAL APPROVAL

1 Definition of product and intended use

1.1 Definition of the construction product

The subject of this approval is the post-installed connection, by anchoring or overlap connection joint, of reinforcing bars (rebars) in existing structures made of normal weight concrete, using the MKT injection adhesive VME in accordance with the regulations for reinforced concrete construction.

Reinforcing bars made of steel with a diameter \varnothing from 8 to 28 mm according to Annex 4 or the tension anchor ZA sizes M12, M16 and M20 according to Annex 5 and 6 and the MKT Injection System VME are used for MKT rebar connections. The steel element is placed into a drilled hole filled with injection adhesive and is anchored via the bond between embedded element, injection mortar and concrete.

1.2 Intended use

The rebar connection may be used in normal weight concrete of a minimum grade of C12/15 and maximum grade C50/60 according to EN 206-1:2000. It may be used in non-carbonated concrete with allowable chloride content of 0.40 % (CL 0.40) related to the cement content according to EN 206-1.

Rebar connections with reinforcing bars and tension anchor ZA may be used under predominantly static loads.

The fire resistance of post-installed rebar connections is not covered by this European technical approval. Fatigue, dynamic or seismic loading of post-installed rebar connections are not covered by this European technical approval.

Rebar connections may only be carried out in a manner, which is also possible with cast-in straight reinforcing bars, e.g. those in the following applications (see Annex 2):

- an overlap joint with existing reinforcement in a building component (Figures 1 and 2),
- anchoring of the reinforcement at a slab or beam support, (e.g. according to Figure 3: end support of a slab, designed simply supported, as well as an appropriate general reinforcement for restraint forces),
- anchoring of reinforcement of building components stressed primarily in compression (Figure 4),
- anchoring of reinforcement to cover the envelope line of tensile force in the bending member (Figure 5).

The post-installed rebar connections may be used in the temperature range of -40 °C to $+80\text{ °C}$ (max short term temperature $+80\text{ °C}$ and max long term temperature $+50\text{ °C}$).

This ETA covers anchoring in bore holes made with hammer drilling, compressed air drilling or wet diamond drilling technique. The post-installed rebar connection may be installed in dry or wet concrete. It must not be installed in flooded holes.

Rebar connections with the tension anchor ZA may be used for the transmission of tensile forces in the direction of the bar axis only. The transmission of shear forces has to be ensured by appropriate measures. Examples for the application are given in Annex 3, Figure 6 to Figure 8.

- The tension anchor ZA made of stainless steel 1.4362, 1.4401, 1.4404 or 1.4571 may be used in structures subject to dry internal conditions and also in structures subject to external atmospheric exposure (including industrial and marine environment), or exposure to permanently damp internal conditions, if no particular aggressive conditions exist. Such particular aggressive conditions are e.g. permanent, alternating immersion in seawater or the splash zone of seawater, chloride atmosphere of indoor swimming pools or atmosphere with extreme chemical pollution (e.g. in desulphurization plants or road tunnels where de-icing materials are used).

- The tension anchor ZA made of high corrosion resistant steel 1.4529 or 1.4565 may be used in structures subject to dry internal conditions and also in structures subject to external atmospheric exposure, in permanently damp internal conditions or in other particular aggressive conditions. Such particular aggressive conditions are e.g. permanent, alternating immersion in seawater or the splash zone of seawater, chloride atmosphere of indoor swimming pools or atmosphere with chemical pollution (e.g. in desulphurization plants or road tunnels where de-icing materials are used).

The provisions made in this European technical approval are based on an assumed working life of the post-installed rebar connection of 50 years. The indications given on the working life cannot be interpreted as a guarantee given by the producer, but are to be regarded only as a means for choosing the right products in relation to the expected economically reasonable working life of the works.

2 Characteristics of the product and methods of verification

2.1 Characteristics of the product

The post-installed rebar connection corresponds to the drawings and provisions given in Annexes 1 to 7. The characteristic material values, dimensions and tolerances not indicated in Annexes 1 to 7 shall correspond to the respective values laid down in the technical documentation⁷ of this European technical approval.

The two components of the injection adhesive are delivered in unmixed condition in cartridges of sizes 385 ml, 585 ml or 1400 ml according to Annex 1. Each cartridge is marked with the identifying mark "MKT Injection adhesive VME" with the processing notes, shelf life, hazard code, curing time and processing time (depending on temperature).

The rebar shall comply with the specifications given in Annex 4. The tension anchor ZA shall comply with the specifications given in Annex 5 and 6 and is marked with the identifying mark of the manufacturing plant, the trade name, the size of rebar and the maximum thickness of the fixture. In addition each tension anchor with connecting thread made of stainless steel is marked with "A4". In addition each tension anchor with connecting thread made of high corrosion resistant steel 1.4529 is marked with "HCR".

2.2 Methods of verification

The assessment of fitness of the post-installed rebar connection for the intended use in relation to the requirements for mechanical resistance and stability and safety in use in the sense of the Essential Requirements 1 and 4 has been made in accordance with the "Guideline for European technical approval of Metal Anchors for Use in Concrete", Part 1 "Anchors in general" and Part 5 "Bonded anchors" and EOTA Technical Report TR 023 "Assessment of post-installed rebar connections"⁸.

In addition to the specific clauses relating to dangerous substances contained in this European technical approval, there may be other requirements applicable to the products falling within its scope (e.g. transposed European legislation and national laws, regulations and administrative provisions). In order to meet the provisions of the Construction Products Directive, these requirements need also to be complied with, when and where they apply.

⁷ The technical documentation of this European technical approval is deposited at the Deutsches Institut für Bautechnik and, as far as relevant for the tasks of the approved bodies involved in the attestation of conformity procedure, is handed over to the approved bodies.

⁸ The Technical Report TR 023 "Assessment of post-installed rebar connections" is published on EOTA website www.EOTA.eu.

3 Evaluation and attestation of conformity and CE marking

3.1 System of attestation of conformity

According to the Decision 96/582/EC of the European Commission⁹ system 2(i) (referred to as System 1) of the attestation of conformity applies.

This system of attestation of conformity is defined as follows:

System 1: Certification of the conformity of the product by an approved certification body on the basis of:

(a) Tasks for the manufacturer:

- (1) factory production control;
- (2) further testing of samples taken at the factory by the manufacturer in accordance with a prescribed test plan;

(b) Tasks for the approved body:

- (3) initial type-testing of the product;
- (4) initial inspection of factory and of factory production control;
- (5) continuous surveillance, assessment and approval of factory production control.

Note: Approved bodies are also referred to as "notified bodies".

3.2 Responsibilities

3.2.1 Tasks for the manufacturer

3.2.1.1 Factory production control

The manufacturer shall exercise permanent internal control of production. All the elements, requirements and provisions adopted by the manufacturer shall be documented in a systematic manner in the form of written policies and procedures, including records of results performed. This production control system shall insure that the product is in conformity with this European technical approval.

The manufacturer may only use initial/raw/constituent materials stated in the technical documentation of this European technical approval.

The factory production control shall be in accordance with the control plan of May 2008 which is part of the technical documentation of this European technical approval. The control plan is laid down in the context of the factory production control system operated by the manufacturer and deposited with Deutsches Institut für Bautechnik.¹⁰

The results of factory production control shall be recorded and evaluated in accordance with the provisions of the control plan.

3.2.1.2 Other tasks for the manufacturer

The manufacturer shall, on the basis of a contract, involve a body which is approved for the tasks referred to in section 3.1 in the field of anchors in order to undertake the actions laid down in section 3.2.2 For this purpose, the control plan referred to in sections 3.2.1.1 and 3.2.2 shall be handed over by the manufacturer to the approved body involved.

The manufacturer shall make a declaration of conformity, stating that the construction product is in conformity with the provisions of this European technical approval.

⁹ Official Journal of the European Communities L 254 of 08.10.1996

¹⁰ The control plan is a confidential part of the European technical approval and only handed over to the approved body involved in the procedure of attestation of conformity. See section 3.2.2.

3.2.2 Tasks for the approved bodies

The approved body shall perform the

- initial type-testing of the product,
 - initial inspection of factory and of factory production control,
 - continuous surveillance, assessment and approval of factory production control,
- in accordance with the provisions laid down in the control plan.

The approved body shall retain the essential points of its actions referred to above and state the results obtained and conclusions drawn in a written report.

The approved certification body involved by the manufacturer shall issue an EC certificate of conformity of the product stating the conformity with the provisions of this European technical approval.

In cases where the provisions of the European technical approval and its control plan are no longer fulfilled the certification body shall withdraw the certificate of conformity and inform Deutsches Institut für Bautechnik without delay.

3.3 CE marking

The CE marking shall be affixed on each packaging of the injection mortar. The letters "CE" shall be followed by the identification number of the approved certification body, where relevant, and be accompanied by the following additional information:

- the name and address of the producer (legal entity responsible for the manufacture),
- the last two digits of the year in which the CE marking was affixed,
- the number of the EC certificate of conformity for the product,
- the number of the European technical approval,
- the number of the guideline for European technical approval.

4 Assumptions under which the fitness of the product for the intended use was favourably assessed

4.1 Manufacturing

The European technical approval is issued for the product on the basis of agreed data/information, deposited with Deutsches Institut für Bautechnik, which identifies the product that has been assessed and judged. Changes to the product or production process, which could result in this deposited data/information being incorrect, should be notified to Deutsches Institut für Bautechnik before the changes are introduced. Deutsches Institut für Bautechnik will decide whether or not such changes affect the approval and consequently the validity of the CE marking on the basis of the approval and if so whether further assessment or alterations to the approval shall be necessary.

4.2 Drafting

Rebar connections must be designed in keeping with good engineering practice. Considering the loads to be anchored, design calculations and design drawings must be produced which can be checked. At least the following items must be stated in the design drawings:

- grade of concrete strength,
- diameter, drilling technique, concrete cover, spacing and embedment depth of the rebar,
- length for markings ℓ_m and h_1 on the injection extension according to Annex 7,

- use of a guide device (drilling aid) for drilling holes close to edges (if necessary),
- kind of preparation of the joint between building component being connected including the diameter and thickness of concrete layer that has to be removed.

4.3 Design

4.3.1 General

The actual position of the reinforcement in the existing structure shall be determined on the basis of the construction documentation and taken into account when designing.

The design of post-installed rebar connections according to Annex 2 and determination of the internal section forces to be transferred in the construction joint shall be verified in accordance with EN 1992-1-1:2004. When ascertaining the tensile force in the rebar, allowance shall be made for the statically effective height of the bonded-in reinforcement.

The tension anchor ZA according to Annexes 5 shall be designed for the welded-on reinforcement steel BSt 500S. The length of the bonded thread c_2 may not be accounted as anchorage.

The verification of the immediate local force transfer to the concrete has been provided.

The verification of the transfer of the loads to be anchored to the building component shall be provided.

The spacing between post-installed rebars respectively tension anchor ZA shall be greater than the minimum of $5 \varnothing$ and 50 mm (according to Annex 4 respectively Annex 5).

4.3.2 Determination of the basic anchorage length

The required basic anchorage length $l_{b,rqd}$ shall be determined in accordance with EN 1992-1-1, Section 8.4.3:

$$l_{b,rqd} = (\varnothing / 4) (\sigma_{sd} / f_{bd})$$

with: \varnothing = diameter of the rebar

σ_{sd} = calculated design stress of the rebar

f_{bd} = design value of bond strength according to Annex 7, Table 7

in consideration of the coefficient related to the quality of bond conditions and of the coefficient related to the bar diameter and of the drilling technique

4.3.3 Determination of the design anchorage length

The required design anchorage length l_{bd} shall be determined in accordance with EN 1992-1-1, Section 8.4.4:

$$l_{bd} = \alpha_1 \alpha_2 \alpha_3 \alpha_4 \alpha_5 l_{b,rqd} \geq l_{b,min}$$

with: $l_{b,rqd}$ = according to section 4.3.2

α_1 = 1.0 for straight bars

α_2 = 0.7...1.0 calculated acc. to EN 1992-1-1, Table 8.2

α_3 = 1.0 because of no transverse reinforcement

α_4 = 1.0 because of no welded transverse reinforcement

α_5 = 0.7...1.0 for influence of transverse pressure acc. to EN 1992-1-1, Table 8.2

$l_{b,min}$ = minimum anchorage length acc. to EN 1992-1-1

= max {0.3 $l_{b,rqd}$; 10 \varnothing ; 100 mm} under tension

= max {0.6 $l_{b,rqd}$; 10 \varnothing ; 100 mm} under compression

In case of diamond wet drilling multiply the values by 1.5.

The maximum permissible embedment depth is given in Annex 1 depending on adhesive temperature and the diameter of the rebar.

4.3.4 Overlap joints

The required design lap length l_0 shall be determined in accordance with EN 1992-1-1, Section 8.7.3:

$$l_0 = \alpha_1 \alpha_2 \alpha_3 \alpha_5 \alpha_6 l_{b,rqd} \geq l_{0,min}$$

with: $l_{b,rqd}$ = according to Section 4.3.2

α_1 = 1.0 for straight bars

α_2 = 0.7...1.0 calculated acc. to EN 1992-1-1, Table 8.2

α_3 = 1.0 because of no transverse reinforcement

α_5 = 0.7...1.0 for influence of transverse pressure acc. to EN 1992-1-1, Table 8.2

α_6 = 1.0...1.5 for influence of percentage of lapped bars relative to the total cross-section area acc. to EN 1992-1-1, Table 8.3

$l_{0,min}$ = minimum lap length acc. to EN 1992-1-1

= max {0.3 $\alpha_6 l_{b,rqd}$; 15 \emptyset ; 200 mm}

In case of diamond wet drilling multiply the values by 1.5.

The maximum permissible embedment depth is given in Annex 1 depending on adhesive temperature and the diameter of the rebar.

4.3.5 Embedment depth for overlap joints

Overlap joint for rebars:

For calculation of the effective embedment depth of overlap joints the concrete cover at end-face of bonded-in rebar c_1 shall be considered (see Annex 4, Figure 9):

$$l_v \geq l_0 + c_1$$

with: l_0 = required lap length acc. to Section 4.3.4 and to EN 1992-1-1

c_1 = concrete cover at end-face of bonded-in rebar (see also Annex 4)

If the clear distance between the overlapping rebars is greater than 4 \emptyset the lap length shall be enlarged by the difference between the clear distance and 4 \emptyset .

Overlap joint for tension anchor ZA:

The effective embedment depth is the same like the lap length $l_0 = l_v$ (see Annex 5, Figure 10).

The total embedment depth l_{tot} shall be determined as follows (see Annex 5, Figure 10):

$$l_{tot} \geq l_0 + c_2$$

with: l_0 = required lap length acc. to Section 4.3.4 and to EN 1992-1-1

c_2 = Length of bonded thread ($c_2 > c_1$ see Annex 5)

If the clear distance between overlapping rods exceeds 4 \emptyset , the overlap length shall be increased by the difference between the actual clear distance and 4 \emptyset .

4.3.6 Concrete cover

The concrete cover required for bonded-in rebars and tension anchor ZA is shown in Annex 6, Table 4, in relation to the drilling method and the hole tolerance.

Furthermore the minimum concrete cover given in EN 1992-1-1, Section 4.4.1.2 shall be observed.

4.3.7 Transverse reinforcement

The requirements of transverse reinforcement in the area of the post-installed rebar connection or of the tension anchor ZA connection shall comply with EN 1992-1-1, Section 8.7.4.

4.3.8 Connection joint

The transfer of shear forces between new concrete and existing structure shall be designed according to EN 1992-1-1. The joints for concreting must be roughened to at least such an extent that aggregate protrude.

In case of a carbonated surface of the existing concrete structure the carbonated layer shall be removed in the area of the post-installed rebar connection with a diameter of $\varnothing + 60$ mm prior to the installation of the new rebar.

The depth of concrete to be removed shall correspond to at least the minimum concrete cover for the respective environmental conditions in accordance with EN 1992-1-1:2004.

The foregoing may be neglected if building components are new and not carbonated and if building components are in dry conditions.

4.4 Installation

The fitness for use of the post-installed rebar connection can only be assumed if the rebar or the tension anchor ZA respectively is installed as follows:

- the installation of post-installed rebar respectively tension anchor ZA shall be done only by suitable trained installer and under supervision on site; the conditions under which an installer may be considered as suitable trained and the conditions for supervision on site are up to the Member States in which the installation is done,
- use of the injection system only as supplied by the manufacturer without exchanging the components of the Injection system,
- installation in accordance with the manufacturer's specifications and drawings using the tools indicated in the technical documentation of this European technical approval,
- checks before rebar installation to ensure that the strength class of the concrete in which the post-installed rebar connection is to be placed is in the range given and is not lower than that of the concrete to which the characteristic loads apply,
- check of concrete being well compacted, e.g. without significant voids,
- check the position of the existing rebars (if the position of existing rebars is not known, it shall be determined using a rebar detector suitable for this purpose as well as on the basis of the construction documentation and then marked on the building component for the overlap joint),
- keeping the anchorage depth as specified in the design drawings,
- keeping of concrete cover and spacing as specified in the design drawings,
- positioning of the drill holes without damaging the reinforcement,
- in case of aborted drill hole the drill hole shall be filled with mortar,
- the post-installed rebar connection must not be installed in flooded holes,
- the drilling and cleaning of the hole and the installation shall be performed only with the equipment specified by the manufacturer according to the manufacturer's installation instructions (see Annexes 8 and 9), it shall be ensured that this equipment is available on site and it is used,
- during curing of the injection adhesive the temperature of the building component must not be less than $+5$ °C and no more than $+40$ °C; observing the curing time given in Annex 7.

5 Recommendations concerning packaging, transport and storage

5.1 Responsibility of the manufacturer

It is in the responsibility of the manufacturer to ensure that the information on the specific conditions according to sections 1 and 2 including Annexes referred to and section 4 is given to those who are concerned. This information may be made by reproduction of the respective parts of the European technical approval. In addition all installation data shall be shown clearly on the package and/or on an enclosed instruction sheet, preferably using illustration(s).

The minimum data required are:

- drill bit diameter,
- diameter of rebar,
- admissible service temperature range,
- curing time of the injection mortar,
- Installation instructions including cleaning of the drill hole,
- reference to any special installation equipment needed,
- identification of the manufacturing batch,

All data shall be presented in a clear and explicit form.

5.2 Packaging, transport and storage

The mortar cartridges shall be protected against sun radiation and shall be stored according to the manufacture's installation instructions in dry condition at temperatures of at least +5 °C to not more than +25 °C.

Mortar cartridges with expired shelf life must no longer be used.

Dipl.-Ing. E. Jasch
President of Deutsches Institut für Bautechnik
Berlin, 4 July 2008

beglaubigt:
Lange

Product description

- Only for design of rebar connections based on EN 1992-1-1:2004
- Non carbonated concrete C12/15 – C50/60 according to EN 206-1:2000
- Reinforcement bars, diameter $\varnothing = 8 \text{ mm} - 28 \text{ mm}$ according to Annex 4, Table 1 or MKT tension anchor ZA acc. to Annex 5, Figure 11
- MKT Injection Adhesive VME
- Maximum embedment depth (adhesive temperature $\geq 20 \text{ }^\circ\text{C}$)
 - max $l_v = 200 \text{ cm}$ for $\varnothing = 8 - 12 \text{ mm}$ (extension pipe outer diameter 10 mm)
 - max $l_v = 280 \text{ cm}$ for $\varnothing = 14 - 28 \text{ mm}$ (extension pipe outer diameter 16 mm)
- Maximum embedment depth (adhesive temperature $5 - 19 \text{ }^\circ\text{C}$)
 - max $l_v = 130 \text{ cm}$ for $\varnothing = 8 - 12 \text{ mm}$ (extension pipe outer diameter 10 mm)
 - max $l_v = 200 \text{ cm}$ for $\varnothing = 14 - 28 \text{ mm}$ (extension pipe outer diameter 16 mm)
- maximum long term temperature $+50 \text{ }^\circ\text{C}$, maximum short term temperature $+80 \text{ }^\circ\text{C}$
- Installation in dry or wet concrete, no installation in flooded holes

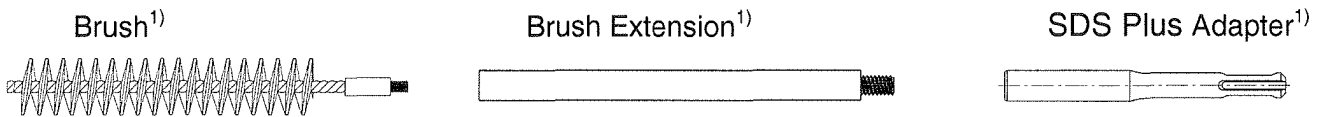
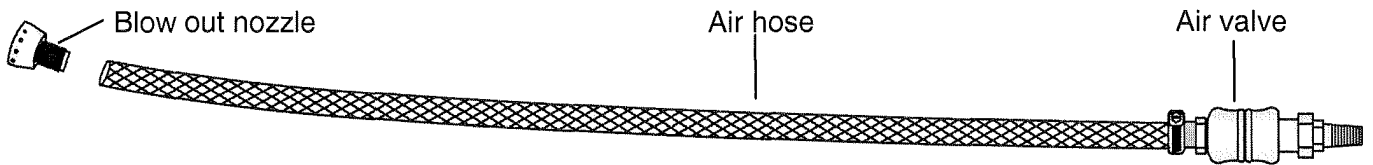

¹⁾ additional cleaning tools for diamond core drilling

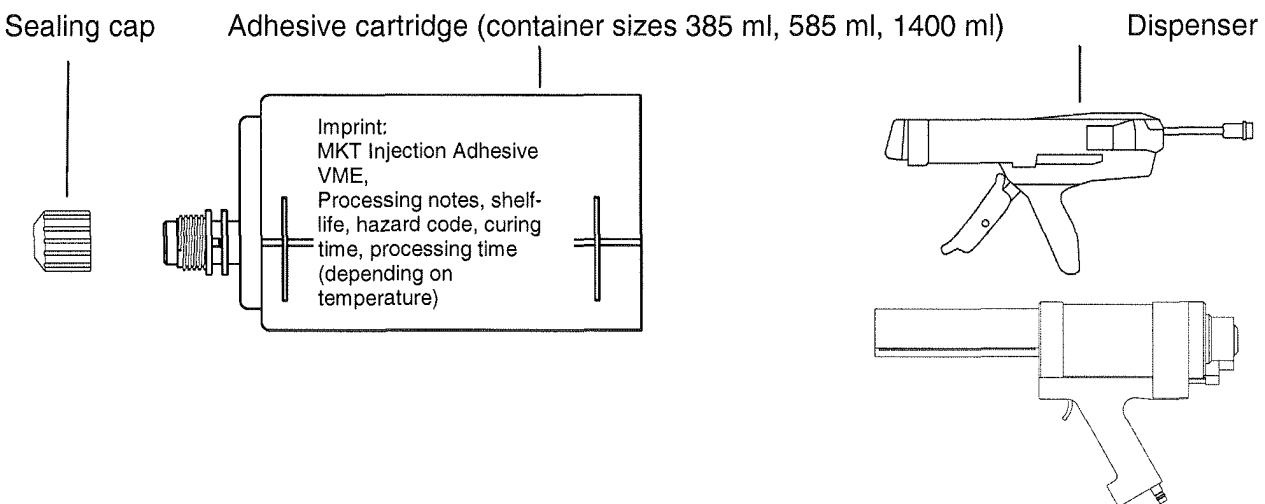
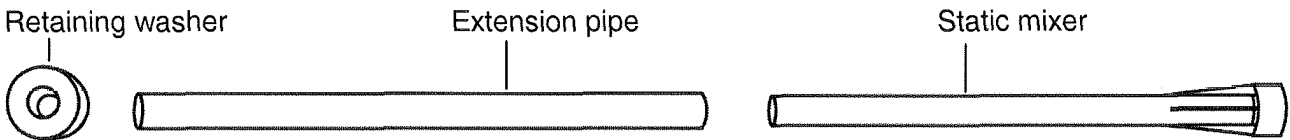

<p>MKT Injection System VME</p>	<p>Annex 1</p>
<p>Product description</p>	<p>of European technical approval ETA- 07/0299</p>

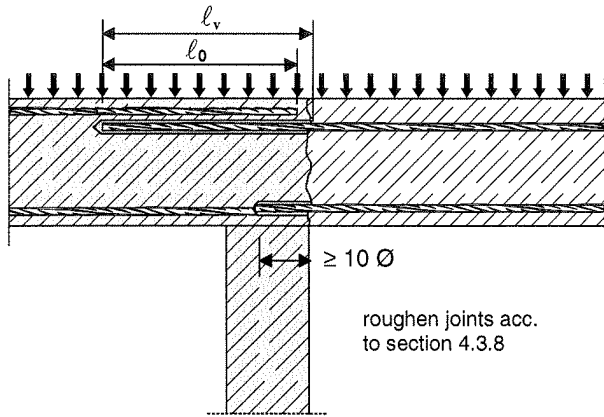

Figure 1: Overlap joint in slabs and beams

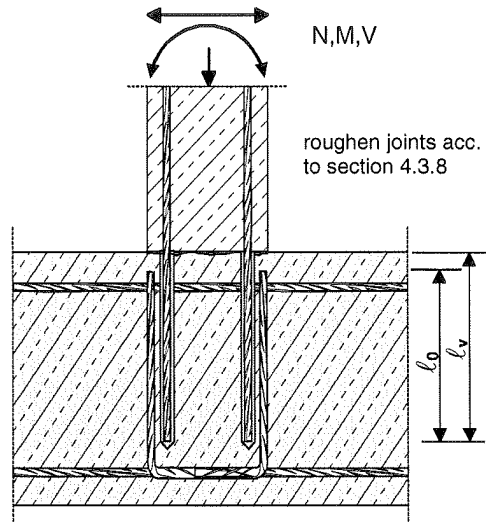

Figure 2: Overlap joint in a foundation of a column or wall where the rebars are stressed in tension

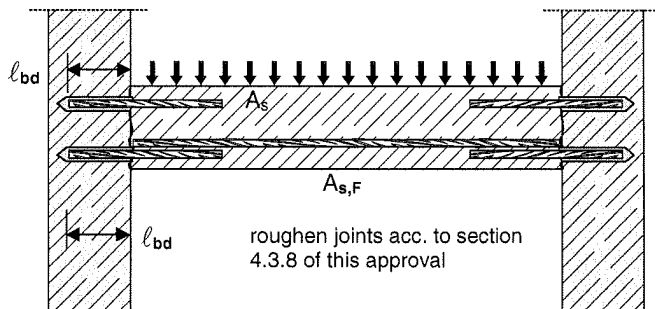

Figure 3: End anchoring of slabs or beams, designed as simply supported

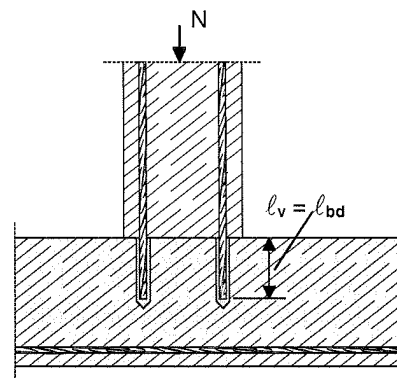

Figure 4: Rebar connection of components stressed primarily in compression. The rebars are stressed in compression.

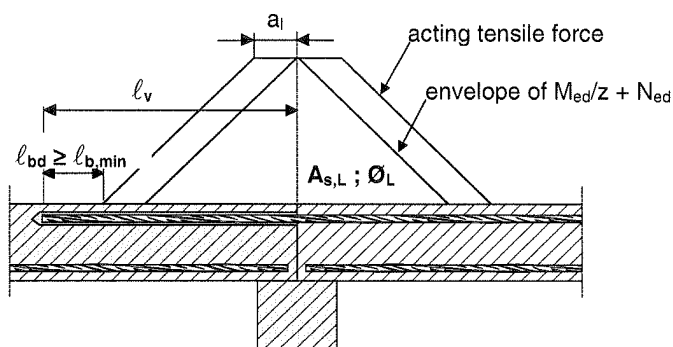

Figure 5: Anchoring of reinforcement to cover the line of acting tensile force

Notes to Figure 1 – 5:

No transverse reinforcement is plotted, the transverse reinforcement as required by EN 1992-1-1 shall be present. The shear transfer between old and new concrete shall be designed according to EN 1992-1-1. Notations and definitions of anchorage and overlap joints see Annex 4.

MKT Injection System VME

Application examples of post-installed rebars

Annex 2

of European technical approval

ETA- 07/0299

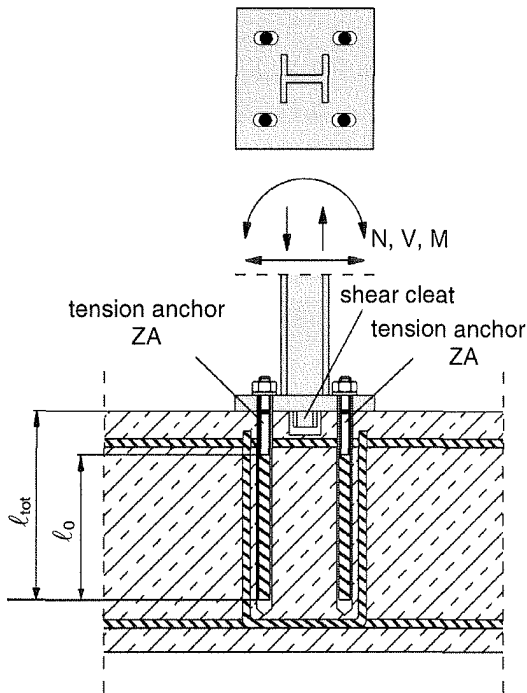

Figure 6: Overlap joint at the foundation of columns

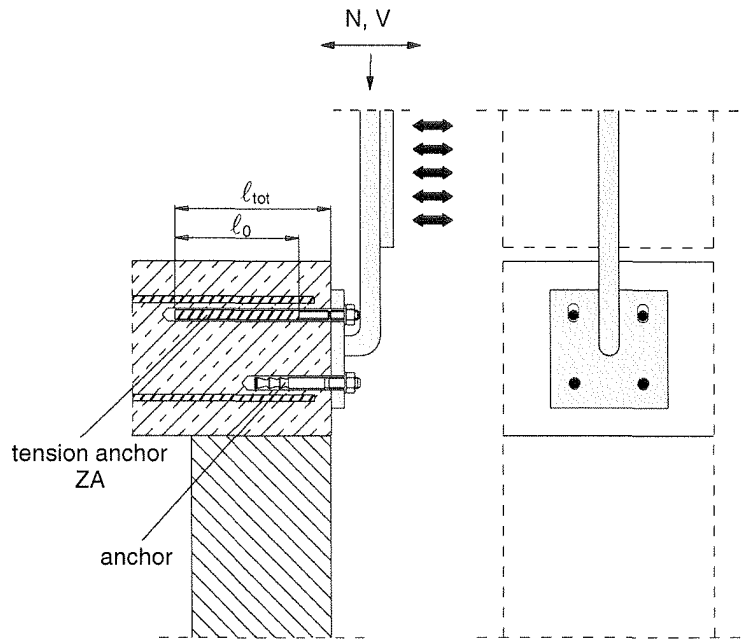

Figure 7: Overlap joint for the anchorage of guardrail posts

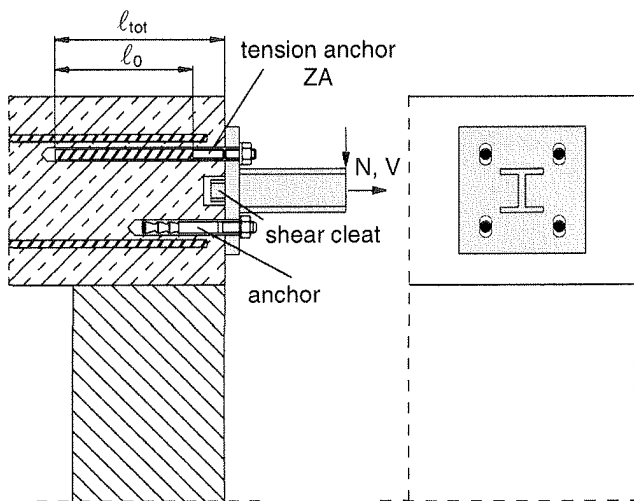

Figure 8: Overlap joint for the anchorage of cantilevers

Note to Figure 6 to 8:

No transverse reinforcement is plotted, the transverse reinforcement as required by EN 1992-1-1 shall be present. Notations and definitions of anchorage and overlap joints see Annex 5.

The tension anchor ZA can only transfer forces towards the bar axis.

Tension forces must be transferred by an overlap joint into the present reinforcement of the member. The transmission of shear forces must be ensured by additional measures, e.g. by shear cleats or anchors with a European technical approval. In the anchor plate the holes for the tension anchor must be designed as slotted holes towards the shear force.

<p>MKT Injection System VME</p>	<p>Annex 3 of European technical approval ETA- 07/0299</p>
<p>Application examples of tension anchor ZA</p>	

Figure 9: General rules for post-installed rebar connections

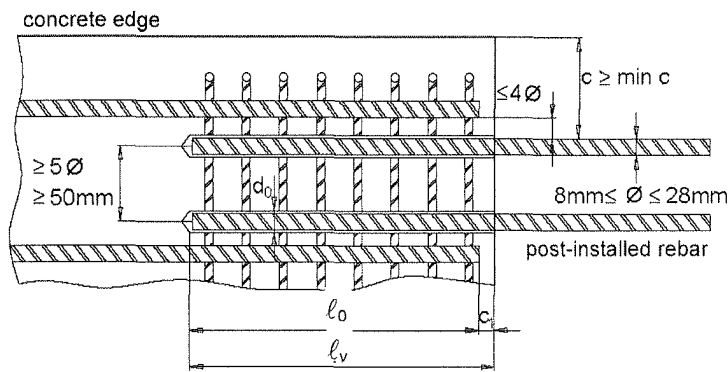

- c concrete cover of post-installed reinforcement
- c₁ concrete cover at front end of cast in place rebar
- min c minimum concrete cover according to Table 1
- Ø diameter of post-installed rebar
- l₀ lap length
- l_v embedment depth
- d₀ nominal drill bit diameter according to Annex 6, Table 5

- Bond strength f_{bd} according to EN 1992-1-1 may be applied
- l_0 and l_v according to sections 4.3.4 and 4.3.5
- Transverse reinforcement according to EN 1992-1-1.
- If the clear distance of overlapping bars is greater than $4 \text{ } \varnothing$ mm, the lap length must be increased by a length equal to the clear space where it exceeds $4 \text{ } \varnothing$ mm.
- The minimum concrete cover according to EN 1992-1-1 shall be kept.

Table 1: Properties of reinforcement bars “rebars”
(referring to EN 1992-1-1, Annex C, Table C.1 and C.2N)

Product form		Bars and de-coiled rods	
Class		B	C
Characteristic yield strength f_{yk} or $f_{0,2k}$ [N/mm ²]		400 to 600	
Minimum value of $k = (f_t/f_y)_k$		≥ 1.08	≥ 1.15 < 1.35
Characteristic strain at maximum force, ϵ_{uk} [%]		≥ 5.0	≥ 7.5
Bendability		Bend / Rebend test	
Maximum deviation from nominal mass (individual bar) [%]	Nominal bar size [mm]		
	≤ 8 > 8	± 6.0 ± 4.5	
Bond: Minimum relative rib area, $f_{R,min}$ (determination acc. to EN 15630)	Nominal bar size [mm]		
	8 - 12 > 12	0.040 0.056	
Maximum outer rebar diameter over the ribs [mm]	$\varnothing + 2h$ Rib height $h \leq 0.07 \varnothing$		

MKT Injection System VME	Annex 4 of European technical approval ETA– 07/0299
General rules for post-installed rebar connections, Properties of reinforcement bars	

Figure 10: General construction rules for the MKT post-installed tension anchor ZA

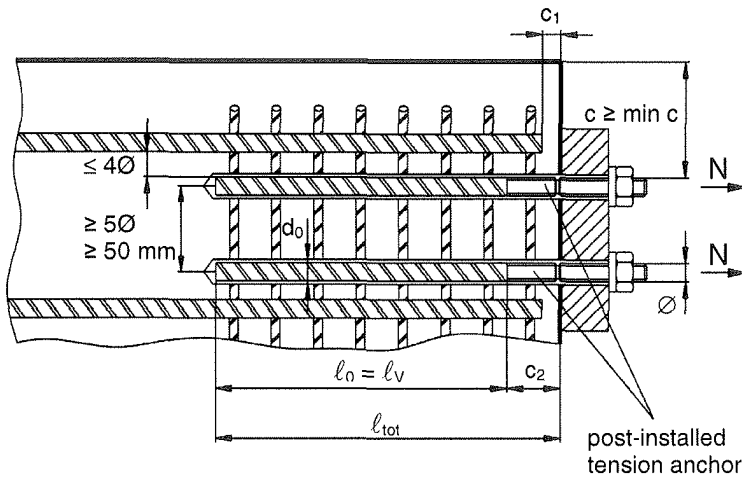

- c concrete cover of post-installed tension anchor
- c₁ concrete cover at front side of cast-in-place rebar
- min c minimum concrete cover according to Table 1
- c₂ length of bonded thread
- Ø diameter of tension anchor
- l₀ lap length
- l_{tot} embedment length
- d₀ nominal drill bit diameter according to Annex 6, Table 5

- Bond strength f_{bd} according to EN 1992-1-1:2005-10 may be applied
- l_0 and l_v according to sections 4.3.4 and 4.3.5
- Transverse reinforcement according to EN 1992-1-1:2005-10.
- If the clear distance of overlapping bars is greater than $4 \varnothing$ or 50 mm, the lap length must be increased by a length equal to the clear space where it exceeds $4 \varnothing$ or 50 mm.
- The minimum concrete cover according to EN 1992-1-1:2005-10 shall be kept.

Figure 11: Tension anchor ZA

Marking: e.g. 12 A4

- Identifying mark of manufacturing plant
- ZA Trade name
- 12 Size of bar / thread
- A4 for stainless steel A4
- HCR for high corrosion resistant steel

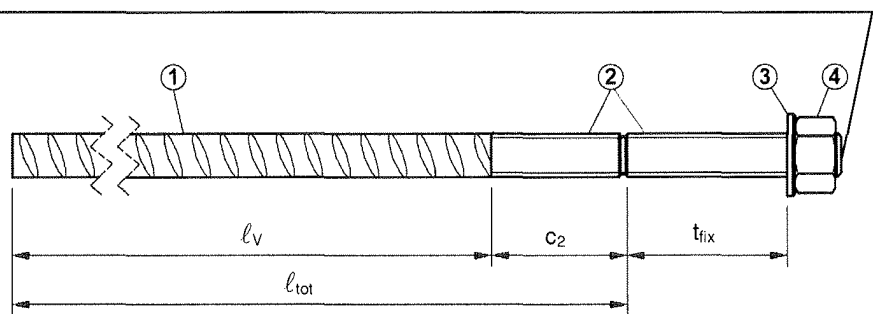

Table 2: Material properties of tension anchor ZA

No.	Description	Material	
		ZA A4	ZA HCR
1	Rebar	Reinforcement bars BSt 500 S, DIN 488	
2	Threaded rod	Stainless steel, 1.4362, 1.4401, 1.4404, 1.4571, EN 10088	High corrosion resistant steel 1.4529, 1.4565, EN 10088
3	Washer		
4	Hexagon nut		

MKT Injection System VME	Annex 5 of European technical approval ETA- 07/0299
General constructions rules for tension anchor ZA, Material properties	

Table 3: Dimensions and installation parameters of tension anchor ZA

Anchor size			M12	M16	M20
Thread diameter		[mm]	12	16	20
Width across nut flats	SW	[mm]	19	24	30
Effective embedment depth	l_v	[mm]	according to structural analysis		
Length of bonded thread	c_2	[mm]	≥ 100	≥ 100	≥ 100
Minimum thickness of fixture	t_{fix}	[mm]	5	5	5
Maximum thickness of fixture	t_{fix}	[mm]	3000	3000	3000
Maximum installation torque	T_{inst}	[Nm]	50	100	150

Table 4: Minimum concrete cover $\min c$ of post-installed rebars and tension anchor ZA depending on drilling method and drilling tolerances

Drilling method	Rebar diameter	Without drilling aid device	With drilling aid device
Hammer drilling and diamond core drilling	< 25 mm	30 mm + 0,06 $l_v \geq 2 \varnothing$	30 mm + 0,02 $l_v \geq 2 \varnothing$
	≥ 25 mm	40 mm + 0,06 $l_v \geq 2 \varnothing$	40 mm + 0,02 $l_v \geq 2 \varnothing$
Compressed air drilling	< 25 mm	50 mm + 0,08 l_v	50 mm + 0,02 l_v
	≥ 25 mm	60 mm + 0,08 l_v	60 mm + 0,02 l_v

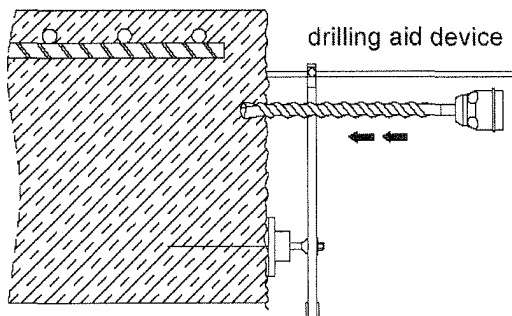
Figure 12: Drilling aid device**Table 5: Dimensions of installation tools**

Rebar diameter \varnothing [mm]	Drill bit / diamond core diameter d_0 [mm]	Blow out nozzle diameter [mm]	Retaining washer diameter [mm]
8	12	10	10
10	14	10	13
12	16	14	15
14	18	14	17
16	20	17	19
20	25	17	24
24	30	27	29
25	32	27	31
26	32	27	31
28	35	27	34

MKT Injection System VME

Dimensions and installation parameters,
Minimum concrete cover, Drilling aid device,
Dimensions of installation tools

Annex 6

of European
technical approval

ETA- 07/0299

Table 6: Maximum working times and minimum curing times

Temperature of base material	Maximum working time [minutes]	Minimum curing time [hours]
+5°C to +9°C	60	72
+10°C to +19°C	45	36
+20°C to +29°C	30	10
+30°C to +39°C	20	6
40°C	12	4

¹⁾ An adhesive temperature greater than + 20 °C reduces the press out forces and accelerates the injection of the adhesive. When using the adhesive in wet concrete the curing times have to be doubled.

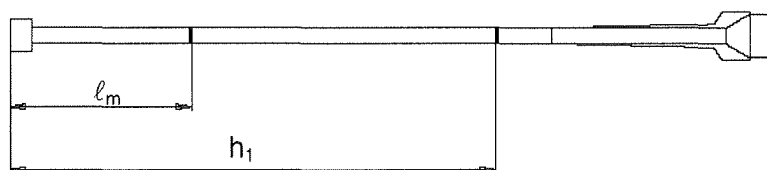
Figure 13: Marking lengths l_m on extension pipe for injection of adhesive

$$\text{Equation 1: } l_m = h_1 \cdot (1,2 \cdot \frac{\varnothing^2}{d_o^2} - 0,2) \text{ [mm]}$$

The marking lengths l_m determined in equation 1 refer to compressed air drilled holes. When using hammer drill or diamond core, the length l_m may be multiplied by 1.10.

l_m	distance from end of retaining washer to marking on extension pipe
h_1	drill hole depth = embedment depth
\varnothing	rebar diameter
d_o	nominal drill bit diameter

Table 7: Design values of ultimate bond stress

Concrete strength class	C12/15	C16/20	C20/25	C25/30	C30/37	C35/45	C40/50	C45/55	C50/60
Design values of ultimate bond stress f_{bd} [N/mm ²] Hammer drilling and compressed air drilling ¹⁾	1.6	2.0	2.3	2.7	3.0	3.4	3.7	4.0	4.3
Diamond core drilling ²⁾	1.6	2.0	2.3	2.7	3.0	3.0	3.4	3.7	3.7

¹⁾ Minimum anchorage lengths $l_{b,min}$ and $l_{o,min}$ according to EN 1992-1-1

²⁾ Minimum anchorage lengths $l_{b,min}$ and $l_{o,min}$ given in the EN 1992-1-1 for anchorages and overlap splices shall be multiplied by the factor 1.5 for diamond core drilling

MKT Injection System VME

**Working and curing times,
Marking length,
Design values of ultimate bond stress**

Annex 7

of European
technical approval

ETA- 07/0299

Installation instructions for hammer drilling and compressed air drilling

Preparations:

- Remove carbonated concrete and roughen concrete surface prior to installation of post-installed rebars.
- Determine position and diameter of existing reinforcement. Only the admissible force of the existing reinforcement can be transmitted into the post-installed rebar connection.
- The drilling aid device must be adjusted towards the existing reinforcement.

Installation steps

- Build drill hole by hammer drilling or compressed air drilling.
- Cleaning of drill hole: Assemble provided blow out nozzles, air hoses and air valve. Place marking on the air hose at a distance from the end equal to the drill hole depth. Open compressed air (≥ 6 bar) valve and blow out 4x from top to bottom and reverse. The air hose marking has to get below the concrete surface in order to ensure cleaning to the very bottom of the hole.
- Place marking on rebar according to designed embedment depth ℓ_v . Check drill hole depth by inserting marked rebar.
- Prepare cartridge with static mixer, extension pipe and retaining washer. The length of the extension pipe has to be appropriate to the drill hole depth. Place marking on the extension pipe according to Annex 7, Equation 1.
- Prior to injection, discard at least a 10 cm line of adhesive until the colour gets consistent.

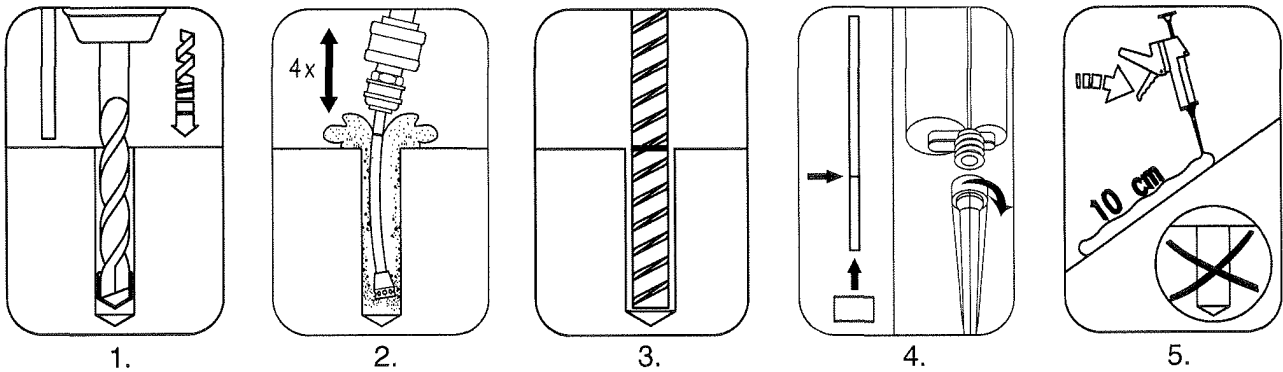

- Inject the adhesive bubble-free starting from the bottom of the drill hole.
- Insert rebar immediately by slightly turning it.
- Excessive adhesive must come out of the drill hole. Otherwise pull out rebar, drill out the hole after curing of the adhesive and start again from No. 2.
- Keep curing times according to Annex 7, Table 6.
- Rebar can be loaded.

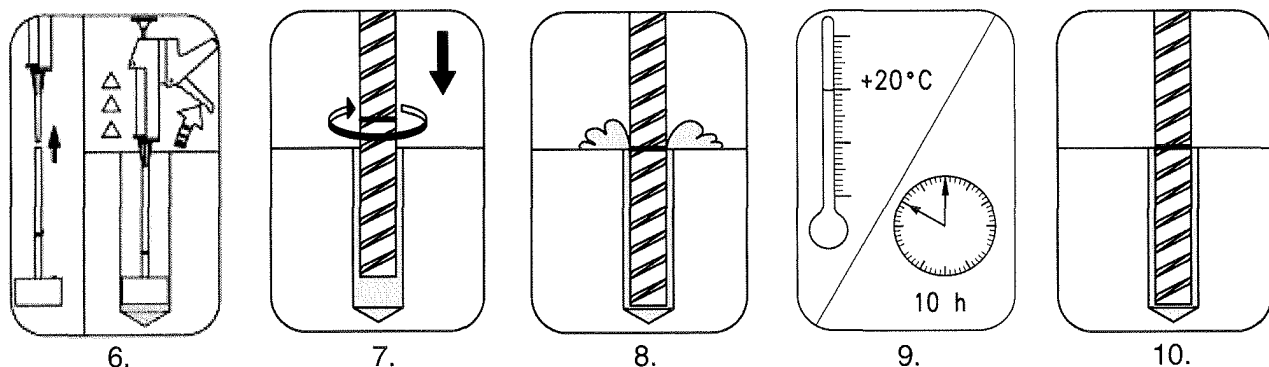

MKT Injection System VME

Installation instructions for hammer drilling and compressed air drilling

Annex 8

of European technical approval

ETA- 07/0299

Installation instructions for diamond core drilling

Preparations:

- Remove carbonated concrete and roughen concrete surface prior to installing post-installed rebars.
- Determine position and diameter of existing reinforcement. Only the admissible force of the existing reinforcement can be transmitted into the post-installed rebar connection.
- The drilling aid device must be adjusted towards the existing reinforcement.

Installation steps:

- Build drill hole by wet diamond core drilling. Remove concrete core completely.
- Flushing of the drill hole: Flush drill hole with water, starting from the bottom, until clear water gets out of the drill hole. Brush drill hole at least 2x by using steel brush driven by drilling machine. Again flush drill hole with water until clear water gets out of the drill hole.
- Cleaning of drill hole: Prepare provided blow out nozzles, air hoses and air valve. Place marking on the air hose at a distance from the end equal to the drill hole depth. Open compressed air (≥ 6 bar) valve and blow out at least 2x from top to bottom and reverse. The air hose marking has to get below the concrete surface in order to ensure cleaning to the very bottom of the hole. Brush drill hole at least 2x by using steel brushes driven by drilling machine. Again blow out drill hole at least 2x.
- Place marking on rebar according to designed embedment depth ℓ_v . Check drill hole depth by inserting marked rebar.
- Prepare cartridge with static mixer, extension pipe and retaining washer. The length of the extension pipe has to be appropriate to the drill hole depth. Place marking on the extension pipe according to Annex 7, Equation 1.

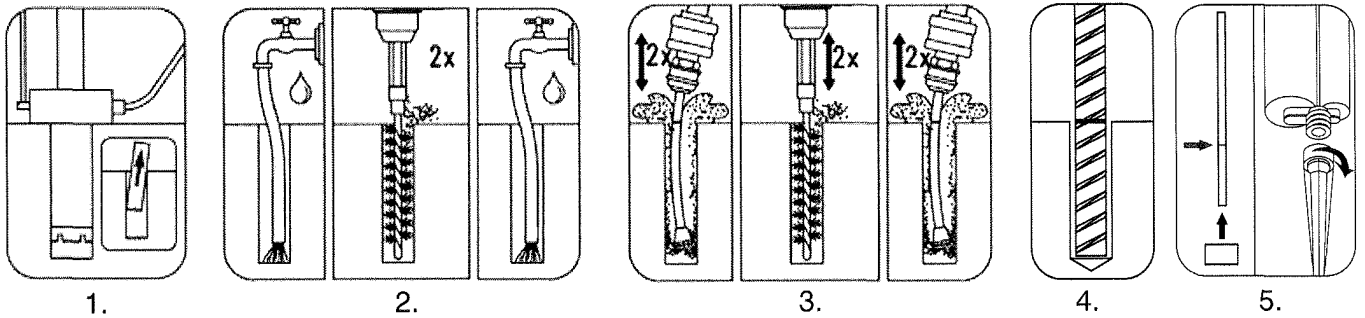

- Prior to injection, discard at least a 10 cm line of adhesive until the colour gets consistent.
- Inject the adhesive bubble-free starting from the bottom of the drill hole.
- Insert rebar immediately by slightly turning it.
- Excessive adhesive must come out of the drill hole. Otherwise pull out rebar, drill out the hole after curing of the adhesive and start again from No. 2.
- Keep curing times according to Annex 7, Table 6.
- Rebar can be loaded.

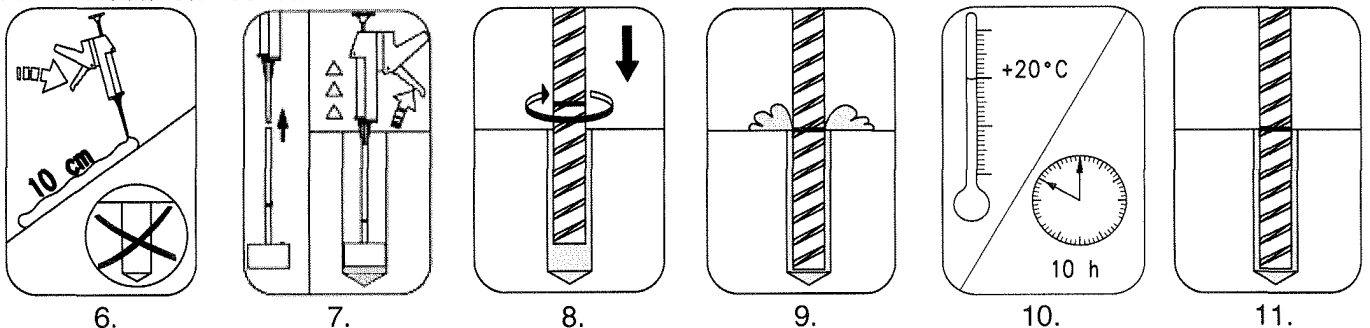

MKT Injection System VME

Installation instructions for diamond core drilling

Annex 9

of European
technical approval

ETA- 07/0299