

European Technical Approval ETA-02/0020

English translation prepared by DIBt - Original version in German language

Handelsbezeichnung <i>Trade name</i>	MKT Einschlaganker E / ES <i>MKT Drop-in Anchor E / ES</i>
Zulassungsinhaber <i>Holder of approval</i>	MKT Metall-Kunststoff-Technik GmbH & Co. KG Auf dem Immel 2 67685 Weilerbach
Zulassungsgegenstand und Verwendungszweck <i>Generic type and use of construction product</i>	Wegkontrolliert spreizender Dübel aus galvanisch verzinktem oder nichtrostendem Stahl in den Größen M6, M8, M10, M12, M16 und M20 zur Verankerung im ungerissenen Beton <i>Deformation-controlled expansion anchor made of galvanised or stainless steel of sizes M6, M8, M10, M12, M16 and M20 for use in non-cracked concrete</i>
Geltungsdauer: <i>Validity:</i>	vom <i>from</i> bis <i>to</i>
Herstellwerk <i>Manufacturing plant</i>	MKT Metall-Kunststoff-Technik GmbH & Co. KG Auf dem Immel 2 67685 Weilerbach

Diese Zulassung umfasst
This Approval contains

15 Seiten einschließlich 8 Anhänge
15 pages including 8 annexes

Diese Zulassung ersetzt
This Approval replaces

ETA-02/0020 mit Geltungsdauer vom 25.11.2010 bis 09.09.2012
ETA-02/0020 with validity from 25.11.2010 to 09.09.2012

I LEGAL BASES AND GENERAL CONDITIONS

- 1 This European technical approval is issued by Deutsches Institut für Bautechnik in accordance with:
 - Council Directive 89/106/EEC of 21 December 1988 on the approximation of laws, regulations and administrative provisions of Member States relating to construction products¹, modified by Council Directive 93/68/EEC² and Regulation (EC) N° 1882/2003 of the European Parliament and of the Council³;
 - Gesetz über das In-Verkehr-Bringen von und den freien Warenverkehr mit Bauprodukten zur Umsetzung der Richtlinie 89/106/EWG des Rates vom 21. Dezember 1988 zur Angleichung der Rechts- und Verwaltungsvorschriften der Mitgliedstaaten über Bauprodukte und anderer Rechtsakte der Europäischen Gemeinschaften (Bauproduktengesetz - BauPG) vom 28. April 1998⁴, as amended by law of 31 October 2006⁵;
 - Common Procedural Rules for Requesting, Preparing and the Granting of European technical approvals set out in the Annex to Commission Decision 94/23/EC⁶;
 - Guideline for European technical approval of "Metal anchors for use in concrete - Part 4: Deformation controlled expansion anchors", ETAG 001-04.
- 2 Deutsches Institut für Bautechnik is authorized to check whether the provisions of this European technical approval are met. Checking may take place in the manufacturing plant. Nevertheless, the responsibility for the conformity of the products to the European technical approval and for their fitness for the intended use remains with the holder of the European technical approval.
- 3 This European technical approval is not to be transferred to manufacturers or agents of manufacturers other than those indicated on page 1, or manufacturing plants other than those indicated on page 1 of this European technical approval.
- 4 This European technical approval may be withdrawn by Deutsches Institut für Bautechnik, in particular pursuant to information by the Commission according to Article 5(1) of Council Directive 89/106/EEC.
- 5 Reproduction of this European technical approval including transmission by electronic means shall be in full. However, partial reproduction can be made with the written consent of Deutsches Institut für Bautechnik. In this case partial reproduction has to be designated as such. Texts and drawings of advertising brochures shall not contradict or misuse the European technical approval.
- 6 The European technical approval is issued by the approval body in its official language. This version corresponds fully to the version circulated within EOTA. Translations into other languages have to be designated as such.

¹ Official Journal of the European Communities L 40, 11 February 1989, p. 12
² Official Journal of the European Communities L 220, 30 August 1993, p. 1
³ Official Journal of the European Union L 284, 31 October 2003, p. 25
⁴ *Bundesgesetzblatt Teil I 1998*, p. 812
⁵ *Bundesgesetzblatt Teil I 2006*, p. 2407, 2416
⁶ Official Journal of the European Communities L 17, 20 January 1994, p. 34

II SPECIFIC CONDITIONS OF THE EUROPEAN TECHNICAL APPROVAL

1 Definition of product/ products and intended use

1.1 Definition of the construction product

The MKT Drop-in Anchor E / ES is an anchor made of galvanised steel in sizes M6, M8, M8x40, M10, M10x30, M12, M12x80, M16, M16x80 and M20, made of stainless steel in sizes M6, M8, M8x40, M10, M12, M12x80, M16, M16x80 and M20 or made of high corrosion resistant steel in sizes M6, M8, M8x40 and M10. The anchor is placed into a drilled hole and anchored by deformation-controlled expansion.

The product (types, sizes) and an illustration of the installed anchor are given in Annex 1.

The fixture shall be anchored with a fastening screw or threaded rod according to Annex 4.

1.2 Intended use

The anchor is intended to be used for anchorages for which requirements for mechanical resistance and stability and safety in use in the sense of the Essential Requirements 1 and 4 of Council Directive 89/106 EEC shall be fulfilled and failure of anchorages made with these products would cause risk to human life and/or lead to considerable economic consequences. The anchor is to be used only for anchorages subject to static or quasi-static loading in reinforced or unreinforced normal weight concrete of strength classes C20/25 at minimum and C50/60 at most according to EN 206-1:2000-12.

The anchor may be anchored in non-cracked concrete only.

MKT Drop-in Anchor made of galvanised steel:

The anchor made of galvanised steel may only be used in structures subject to dry internal conditions.

MKT Drop-in Anchor made of stainless steel:

The anchor made of stainless steel may be used in structures subject to dry internal conditions and also in structures subject to external atmospheric exposure (including industrial and marine environment), or exposure in permanently damp internal conditions, if no particular aggressive conditions exist. Such particular aggressive conditions are e.g. permanent, alternating immersion in seawater or the splash zone of seawater, chloride atmosphere of indoor swimming pools or atmosphere with extreme chemical pollution (e.g. in desulphurization plants or road tunnels where de-icing materials are used).

MKT Drop-in anchor made of high corrosion resistant steel:

The anchor made of high corrosion resistant steel may be used in structures subject to dry internal conditions and also in structures subject to external atmospheric exposure, in permanently damp internal conditions or in other particular aggressive conditions. Such particular aggressive conditions are e.g. permanent, alternating immersion in seawater or the splash zone of seawater, chloride atmosphere of indoor swimming pools or atmosphere with chemical pollution (e.g. in desulphurization plants or road tunnels where de-icing materials are used).

The provisions made in this European technical Approval are based on an assumed intended working life of the anchor of 50 years. The indications given on the working life cannot be interpreted as a guarantee given by the producer, but are to be regarded only as a means for choosing the right products in relation to the expected economically reasonable working life of the works.

2 Characteristics of product and methods of verification

2.1 Characteristics of product

The anchor corresponds to the drawings and provisions given in Annex 2. The characteristic material values, dimensions and tolerances of the anchor not indicated in Annex 2 shall correspond to the respective values laid down in the technical documentation⁷ of this European technical approval.

The characteristic anchor values for the design of anchorages are given in Annexes 5 to 6.

Each anchor is marked according to Annex 2 with the identifying mark of the producer, the anchor identity and the thread size. Each anchor made of stainless steel is marked with the additional letters "A4" and each anchor made of high corrosion resistant steel is marked with the additional letters "HCR".

The anchor shall only be packaged and supplied as a complete unit.

2.2 Methods of verification

The assessment of fitness of the anchor for the intended use in relation to the requirements for mechanical resistance and stability and safety in use in the sense of the Essential Requirements 1 and 4 has been made in accordance with the "Guideline for European technical approval of Metal Anchors for Use in Concrete", Part 1 "Anchors in general" and Part 4 "Deformation-controlled expansion anchors" on the basis of Option 7.

In addition to the specific clauses relating to dangerous substances contained in this European technical approval, there may be other requirements applicable to the products falling within its scope (e.g. transposed European legislation and national laws, regulations and administrative provisions). In order to meet the provisions of the Construction Products Directive, these requirements need also to be complied with, when and where they apply.

3 Evaluation and attestation of conformity and CE marking

3.1 System of attestation of conformity

According to the decision 96/582/EG of the European Commission⁸ the system 2(i) (referred to as System 1) of attestation of conformity applies.

This system of attestation of conformity is defined as follows:

System 1: Certification of the conformity of the product by an approved certification body on the basis of:

- (a) Tasks for the manufacturer:
 - (1) factory production control;
 - (2) further testing of samples taken at the factory by the manufacturer in accordance with a prescribed test plan;

⁷ The technical documentation of this European technical approval is deposited at the Deutsches Institut für Bautechnik and, as far as relevant for the tasks of the approved bodies involved in the attestation of conformity procedure, is handed over to the approved bodies.

⁸ Official Journal of the European Communities L 254 of 08.10.1996

- (b) Tasks for the approved body:
- (3) initial type-testing of the product;
 - (4) initial inspection of factory and of factory production control;
 - (5) continuous surveillance, assessment and approval of factory production control.

Note: Approved bodies are also referred to as "notified bodies".

3.2 Responsibilities

3.2.1 Tasks of the manufacturer

3.2.1.1 Factory production control

The manufacturer shall exercise permanent internal control of production. All the elements, requirements and provisions adopted by the manufacturer shall be documented in a systematic manner in the form of written policies and procedures, including records of results performed. This production control system shall insure that the product is in conformity with this European technical approval.

The manufacturer may only use initial / raw / constituent materials stated in the technical documentation of this European technical approval.

The factory production control shall be in accordance with the control plan which is part of the technical documentation of this European technical approval. The control plan is laid down in the context of the factory production control system operated by the manufacturer and deposited at Deutsches Institut für Bautechnik.⁹

The results of factory production control shall be recorded and evaluated in accordance with the provisions of the control plan.

3.2.1.2 Other tasks of manufacturer

The manufacturer shall, on the basis of a contract, involve a body which is approved for the tasks referred to in section 3.1 in the field of anchors in order to undertake the actions laid down in section 3.2.2. For this purpose, the control plan referred to in sections 3.2.1.1 and 3.2.2 shall be handed over by the manufacturer to the approved body involved.

The manufacturer shall make a declaration of conformity, stating that the construction product is in conformity with the provisions of this European technical approval.

3.2.2 Tasks of approved bodies

The approved body shall perform the following tasks in accordance with the provisions laid down in the control plan:

- initial type-testing of the product,
- initial inspection of factory and of factory production control,
- continuous surveillance, assessment and approval of factory production control.

The approved body shall retain the essential points of its actions referred to above and state the results obtained and conclusions drawn in a written report.

The approved certification body involved by the manufacturer shall issue an EC certificate of conformity of the product stating the conformity with the provisions of this European technical approval.

In cases where the provisions of the European technical approval and its control plan are no longer fulfilled the certification body shall withdraw the certificate of conformity and inform Deutsches Institut für Bautechnik without delay.

⁹

The control plan is a confidential part of the documentation of the European technical approval, but not published together with the European technical approval and only handed over to the approved body involved in the procedure of attestation of conformity.
See section 3.2.2.

3.3 CE marking

The CE marking shall be affixed on each packaging of anchors. The letters "CE" shall be followed by the identification number of the approved certification body, where relevant, and be accompanied by the following additional information:

- the name and address of the producer (legal entity responsible for the manufacturer),
- the last two digits of the year in which the CE marking was affixed,
- the number of the EC certificate of conformity for the product,
- the number of the European technical approval,
- the number of the guideline for European technical approval,
- use category (ETAG 001-1, Option 7),
- size.

4 Assumptions under which the fitness of the product for the intended use was favourably assessed

4.1 Manufacturing

The European technical approval is issued for the product on the basis of agreed data/information, deposited with Deutsches Institut für Bautechnik, which identifies the product that has been assessed and judged. Changes to the product or production process, which could result in this deposited data/information being incorrect, should be notified to Deutsches Institut für Bautechnik before the changes are introduced. Deutsches Institut für Bautechnik will decide whether or not such changes affect the European technical approval and consequently the validity of the CE marking on the basis of the European technical approval and if so whether further assessment or alterations to the European technical approval shall be necessary.

4.2 Design of anchorages

The fitness of the anchor for the intended use is given under the following conditions:

The anchorages are designed in accordance with the "Guideline for European technical approval of Metal Anchors for Use in Concrete", Annex C, Method A, under the responsibility of an engineer experienced in anchorages and concrete work.

Verifiable calculation notes and drawings are prepared taking account of the loads to be anchored.

The position of the anchor is indicated on the design drawings (e.g. position of the anchor relative to reinforcement or to supports).

The strength class and the length of the fastening screw or threaded rod shall be defined by the designing engineer. The choice of the length shall account for the available thread length, the minimum screwing depth, the thickness of fixture and tolerances of member and fixture. The strength class and the minimum screwing depth of the fastening screw or threaded rod shall be met the requirements according to Annex 4.

4.3 Installation of anchors

The fitness for use of the anchor can only be assumed if the anchor is installed as follows:

- Anchor installation carried out by appropriately qualified personnel and under the supervision of the person responsible for technical matters of the site.
- Use of the anchor only as supplied by the manufacturer without exchanging the components of an anchor.
- Anchor installation in accordance with the manufacturer's specifications and drawings and using the appropriate tools;

- Checks before placing the anchor to ensure that the strength class of the concrete in which the anchor is to be placed is in the range given and is not lower than that of the concrete to which the characteristic loads apply.
- Check of concrete being well compacted, e.g. without significant voids.
- Edge distance and spacing not less than the specified values without minus tolerances.
- Positioning of the drill holes without damaging the reinforcement.
- Drill hole by hammer drilling only.
- In case of aborted hole: new drilling at a minimum distance away of twice the depth of the aborted hole or smaller distance if the aborted drill hole is filled with high strength mortar and if under shear or oblique tension load it is not in the direction of load application.
- Clearing of the hole of drilling dust.
- Anchor installation acc. to manufacturer's instructions given in Annex 8.
- The fastening screw or threaded rod shall correspond to the requirements given in Annex 4.
- Installation torque moments are not required for functioning of the anchor. However, the torque moments given in Annex 4 must not be exceeded.

5 Responsibility of the manufacturer

It is in the responsibility of the manufacturer to ensure that the information on the specific conditions according to 1 and 2 including Annexes referred to as well as sections 4.2 and 4.3 is given to those who are concerned. This information may be made by reproduction of the respective parts of the European technical approval. In addition all installation data shall be shown clearly on the package and/or on an enclosed instruction sheet, preferably using illustration(s).

The minimum data required are:

- drill bit diameter,
- thread diameter,
- minimum effective anchorage depth,
- available thread length and minimum screwing depth of the fastening screw
- minimum hole depth,
- torque moment,
- information on the installation procedure, including cleaning of the hole, preferably by means of an illustration,
- reference to any special installation equipment needed,
- identification of the manufacturing batch.

All data shall be presented in a clear and explicit form.

Uwe Bender
Head of Department

beglaubigt:
Bürger

Anchor size

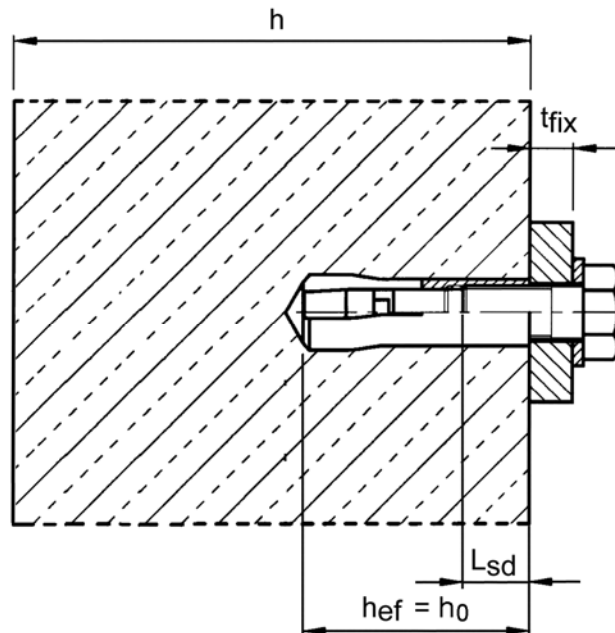
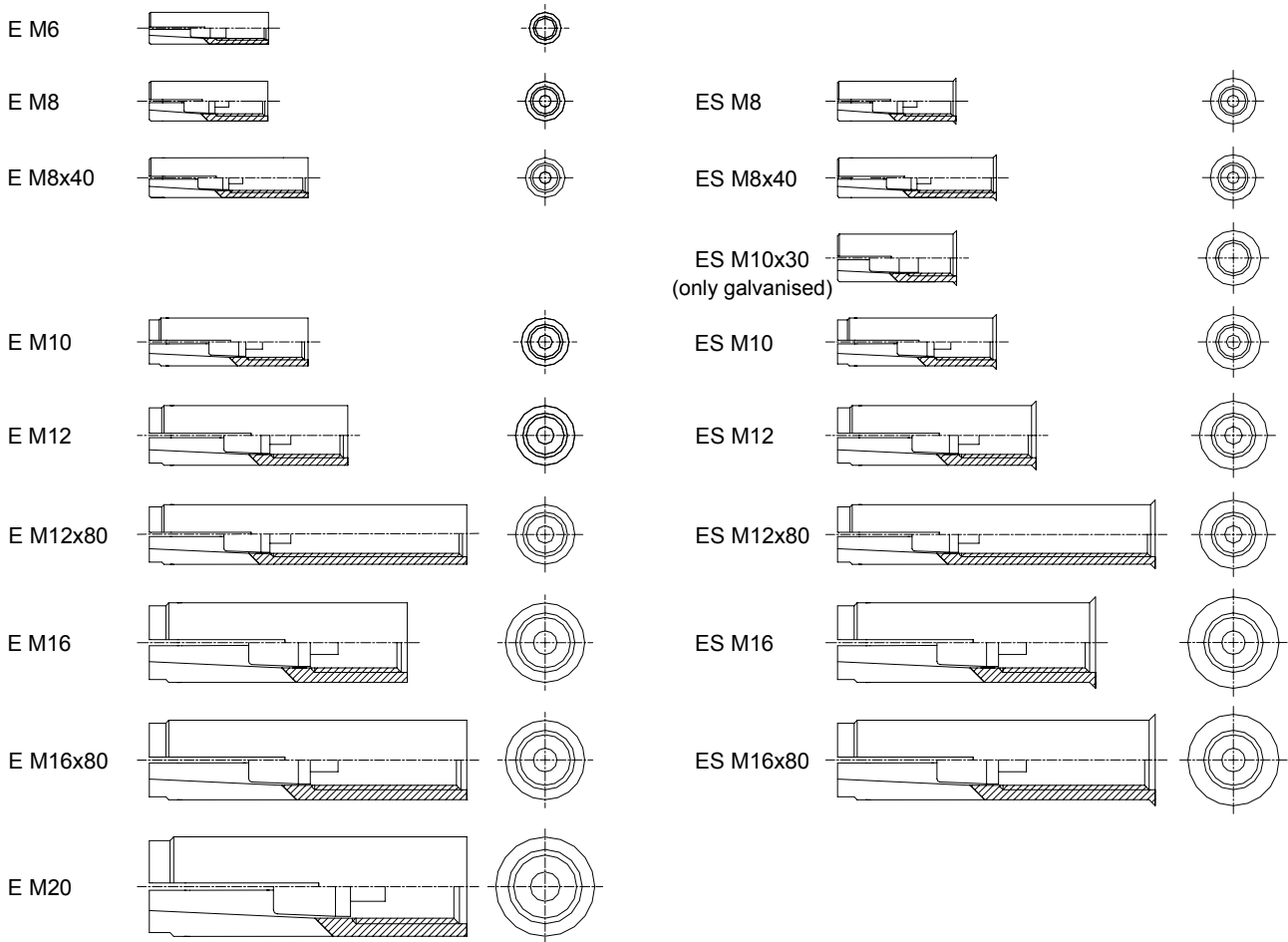

MKT Drop-in anchor E / ES

Product and intended use

Annex 1
of European
technical approval
ETA-02/0020

Anchor sleeve

Marking: e.g.: \diamond E M8

A4 additional marking of stainless steel A4

\diamond Identifying mark of manufacturing plant

HCR additional marking of high corrosion resistant steel HCR

E Anchor identity

M8 Size of thread

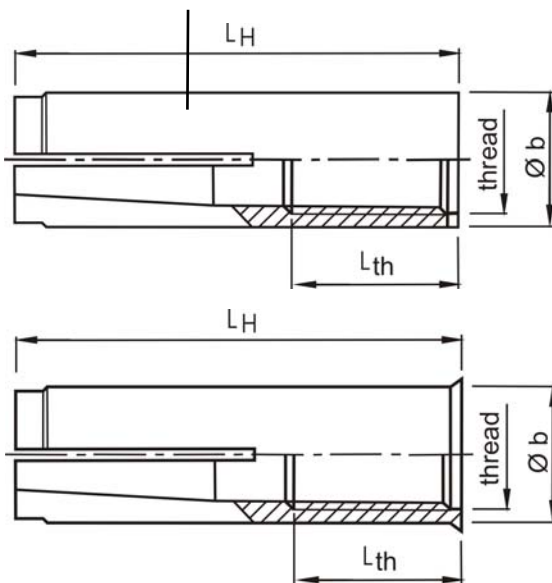

Cone

Size M6 and M10x30

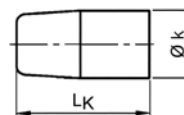

Size M8 – M20

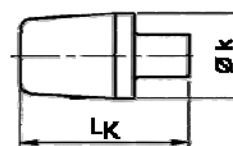

Table 1: Dimensions [mm]

Anchor size	Anchor sleeve				Cone	
	thread	Ø b	L _H	L _{th}	Ø k	L _k
M6	M6	8	30	13	5.0	13
M8	M8	10	30	13	6.5	12
M8x40	M8	10	40	20		
M10x30	M10	12	30	12	8.2	12
M10	M10	12	40	15	8.2	16
M12	M12	15	50	18	10.3	20
M12x80	M12	15	80	45		
M16	M16	19.7	65	23	13.8	29
M16x80	M16	19.7	80	38		
M20	M20	24.7	80	34	16.5	30

Table 2: Designation of anchor parts and material

Part	Designation	Steel, zinc plated	Stainless steel A4	High corrosion resistant steel HCR
1	Anchor sleeve	Cold formed or machining steel, zinc plated, EN ISO 4042	Stainless steel, 1.4401, 1.4404, 1.4571, 1.4362, EN 10088, Property class 70, acc. to EN ISO 3505	Stainless steel, 1.4529, 1.4565, EN 10088, Property class 70, acc. to EN ISO 3506
2	Cone	Steel for cold forming acc. to EN 10263-2	Stainless steel, 1.4401, 1.4404, 1.4571, 1.4362, EN 10088	

MKT Drop-in anchor E / ES

**Dimensions,
Designation of anchor parts and materials**

Annex 2

of European technical approval

ETA-02/0020

Setting tool for marking

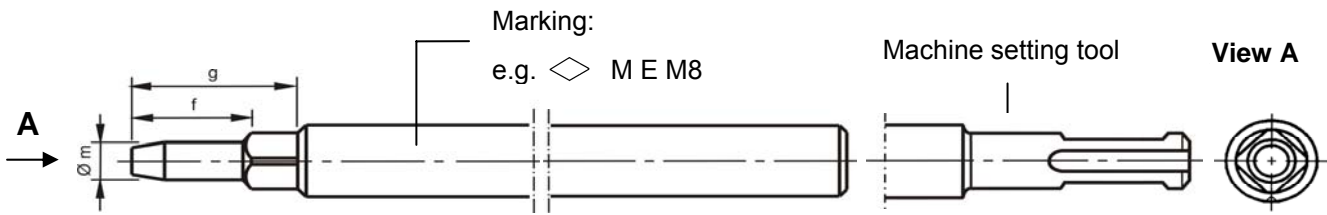

Verification of correct installation with setting tool marking

The setting tool leaves a visible marking after correct installation.

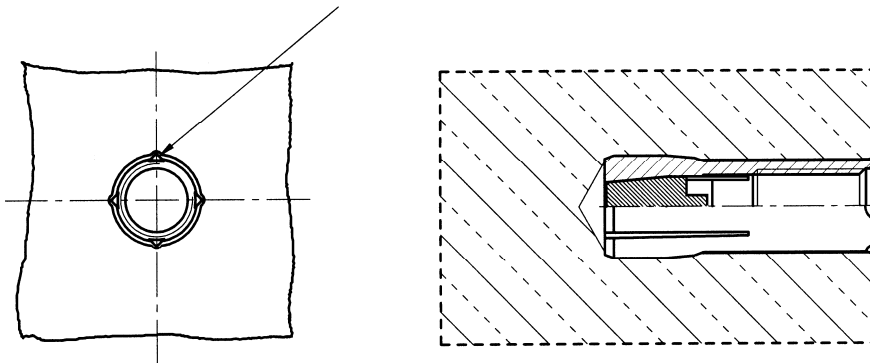

Setting tool

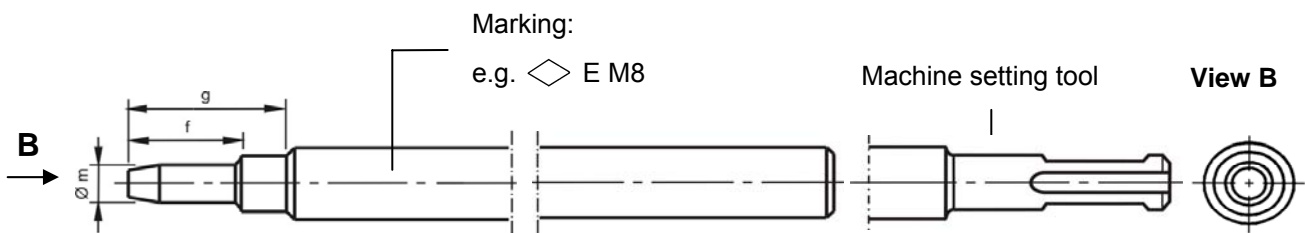

Table 3: Dimensions of setting tools [mm]

Anchor size	Ø m	f	g
M6	4.9	17	27
M8	6.4	18	28
M8x40	6.4	28	38
M10x30	8.0	18	28
M10	8.0	24	34
M12	10.0	30	40
M12x80	10.0	60	70
M16	13.5	36	46
M16x80	13.5	51	61
M20	16.5	50	60

MKT Drop-in anchor E / ES

Dimensions of setting tools and verification of correct installation

Annex 3

of European technical approval

ETA-02/0020

Table 4: Installation parameters

Anchor size		M6	M8	M8x40	M10x30	M10	M12	M12x80	M16	M16x80	M20
Depth of drill hole	$h_0 =$ [mm]	30	30	40	30	40	50	80	65	80	80
Drill hole diameter	$d_0 =$ [mm]	8	10	10	12	12	15	15	20	20	25
Cutting diameter of drill bit	$d_{cut} \leq$ [mm]	8.45	10.45	10.45	12.5	12.5	15.5	15.5	20.55	20.55	25.55
Max. installation torque ¹⁾	$T_{inst} \leq$ [Nm]	4	8	8	15	15	35	35	60	60	120
Diameter of clearance hole in the fixture	$d_f \leq$ [mm]	7	9	9	12	12	14	14	18	18	22
Available thread length	L_{th} [mm]	13	13	20	12	15	18	45	23	38	34
Minimum screw-in depth	L_{sdmin} [mm]	7	9	9	10	11	13	13	18	18	22
Steel, zinc plated											
Minimum thickness of member	h_{min} [mm]	100	100	100	120	120	130	130	160	160	200
Minimum spacing	s_{min} [mm]	55	60	80	100	100	120	120	150	150	160
Minimum edge distance	c_{min} [mm]	95	95	95	115	135	165	165	200	200	260
Stainless steel A4, HCR											
Minimum thickness of member	h_{min} [mm]	100	100	100	—	130	140	140	160	160	250
Minimum spacing	s_{min} [mm]	50	60	80	—	100	120	120	150	150	160
Minimum edge distance	c_{min} [mm]	80	95	95	—	135	165	165	200	200	260

¹⁾ If the screw or threaded rod is otherwise secured against unscrewing, the torque can be omitted.

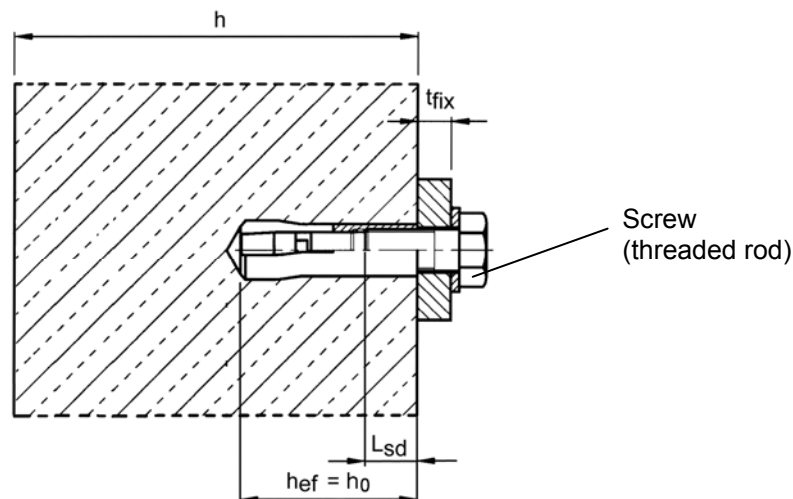

Requirements of the fastening screw or the threaded rod and nut according to the engineering documents:

- Minimum screw-in depth L_{sdmin} see Table 4
- The length of screw or the threaded rod shall be determined depending on the thickness of fixture t_{fix} , available thread length L_{th} (= maximum screw-in depth) and the minimum screw-in depth L_{sdmin} .
- $A_5 > 8$ % ductility

Steel, zinc plated

- Property class 4.6 / 5.6 / 5.8 or 8.8 according to EN ISO 898-1 or EN 20898-2

Stainless steel A4

- Material 1.4401; 1.4404; 1.4578; 1.4571; 1.4439; 1.4362 EN 10088
- Property class 70 or 80 according to EN ISO 3506

High corrosion resistant steel (HCR)

- Material 1.4529; 1.4565 EN 10088
- Property class 70 or 80 according to EN ISO 3506

MKT Drop-in anchor E / ES

Installation parameters

Annex 4

of European
technical approval

ETA-02/0020

Table 5: Design method A – Characteristic values for tension loads

Anchor size		M6 ¹⁾	M8 ¹⁾	M8x40	M10x30 ¹⁾	M10	M12 M12x80	M16 M16x80	M20	
Steel failure, Steel zinc plated										
Characteristic resistance Steel 4.6	$N_{Rk,s}$ [kN]	8.0	14.6	23.2		33.7	62.8	98.0		
Partial safety factor	γ_{Ms} ³⁾ [-]	2.0								
Characteristic resistance Steel 5.6	$N_{Rk,s}$ [kN]	10.0	18.3	18.0	20.2	42.1	78.3	122.4		
Partial safety factor	γ_{Ms} ³⁾ [-]	2.0		1.5		2.0				
Characteristic resistance Steel 5.8	$N_{Rk,s}$ [kN]	10.0	18.3	18.0	20.2	42.1	67.1	106.4		
Partial safety factor	γ_{Ms} ³⁾ [-]	1.5					1.6			
Characteristic resistance Steel 8.8	$N_{Rk,s}$ [kN]	15.0	19.9	18.0	20.2	43.0	67.1	106.4		
Partial safety factor	γ_{Ms} ³⁾ [-]	1.5					1.6			
Steel failure, Stainless steel A4, HCR										
Characteristic resistance	$N_{Rk,s}$ [kN]	14.1	23.3	—	29.4	50.2	83.8	133.0		
Partial safety factor	γ_{Ms} ³⁾ [-]	1.87								
Pull out failure, Steel zinc plated										
Characteristic resistance in concrete C20/25	$N_{Rk,p}$ [kN]	²⁾	²⁾	9	²⁾	²⁾	²⁾	²⁾	²⁾	
Increasing factor for $N_{Rk,p}$	ψ_C	C30/37 [-]		1.12						
		C40/50 [-]		1.23						
		C50/60 [-]		1.30						
Partial safety factor	γ_{Mp} ^{3) 4)} [-]			1.80						
Pull out failure, Stainless steel A4, HCR										
Characteristic resistance in concrete C20/25	$N_{Rk,p}$ [kN]	²⁾	²⁾	9	—	²⁾	²⁾	²⁾	²⁾	
Increasing factor for $N_{Rk,p}$	ψ_C	C30/37 [-]		1.22						
		C40/50 [-]		1.41						
		C50/60 [-]		1.55						
Partial safety factor	γ_{Mp} ^{3) 4)} [-]			1.50						
Concrete cone failure and splitting, Steel zinc plated										
Effective anchorage depth	$h_{ef} = h_0$ [mm]	30	30	40	30	40	50	65	80	
Spacing	$S_{cr,N}$ [mm]	3 h_{ef}								
	$S_{cr,Sp}$ [mm]	190	190	190	230	270	330	400	520	
Edge distance	$C_{cr,N}$ [mm]	1.5 h_{ef}								
	$C_{cr,Sp}$ [mm]	95	95	95	115	135	165	200	260	
Partial safety factor	$\gamma_{Mc} = \gamma_{M,sp}$ ^{3) 4)} [-]	1.8	2.1	1.8						
Concrete cone failure and splitting, Stainless steel A4, HCR										
Effective anchorage depth	$h_{ef} = h_0$ [mm]	30 ⁵⁾	30	40	—	40	50	65	80	
Spacing	$S_{cr,N}$ [mm]	3 h_{ef}								
	$S_{cr,Sp}$ [mm]	160	190	190	—	270	330	400	520	
Edge distance	$C_{cr,N}$ [mm]	1.5 h_{ef}								
	$C_{cr,Sp}$ [mm]	80	95	95	—	135	165	200	260	
Partial safety factor	$\gamma_{Mc} = \gamma_{M,sp}$ ^{3) 4)} [-]	1.5								

¹⁾ Use restricted to anchoring of structural components statically indeterminate

²⁾ Pullout failure mode not decisive

³⁾ In absence of other national regulations

⁴⁾ The partial safety factor γ_2 is included

⁵⁾ For proof against concrete cone failure as per ETAG 001, Annex C, Eq. 5.2a, $N_{Rk,c}^0$ must be multiplied by the factor $(25/f_{ck,cube})^{0.2}$

MKT Drop-in anchor E / ES

**Design method A,
Characteristic values for tension loads**

Annex 5

of European
technical approval

ETA-02/0020

Table 6: Design method A – Characteristic values for shear loads

Anchor size			M6	M8	M8x40	M10x30	M10	M12 M12x80	M16 M16x80	M20
Steel failure without lever arm, Steel zinc plated										
Characteristic resistance Steel 4.6	$V_{Rk,s}$	[kN]	4.0	7.3		11.6	9.6	16.8	31.3	49.0
Partial safety factor	$\gamma_{Ms}^{1)}$	[-]	1.67							
Characteristic resistance Steel 5.6	$V_{Rk,s}$	[kN]	5.0	9.1		10.1	9.6	21.1	39.2	61.2
Partial safety factor	$\gamma_{Ms}^{1)}$	[-]	1.67			1.25	1.67			
Characteristic resistance Steel 5.8	$V_{Rk,s}$	[kN]	5.0	6.9		10.1	7.2	21.1	33.5	53.2
Partial safety factor	$\gamma_{Ms}^{1)}$	[-]	1.25				1.33			
Characteristic resistance Steel 8.8	$V_{Rk,s}$	[kN]	7.5	6.9		10.1	7.2	21.1	33.5	53.2
Partial safety factor	$\gamma_{Ms}^{1)}$	[-]	1.25				1.33			
Steel failure without lever arm, Stainless steel A4, HCR										
Characteristic resistance (property class 70)	$V_{Rk,s}$	[kN]	7.0	10.6	–	13.4	25.1	41.9	66.5	
Partial safety factor	$\gamma_{Ms}^{1)}$	[-]	1.56							
Steel failure with lever arm, Steel zinc plated										
Characteristic resistance Steel 4.6	$M_{Rk,s}^0$	[Nm]	6.1	15		30	30	52	133	259
Partial safety factor	$\gamma_{Ms}^{1)}$	[-]	1.67							
Characteristic resistance Steel 5.6	$M_{Rk,s}^0$	[Nm]	7.6	19		37	37	65	166	324
Partial safety factor	$\gamma_{Ms}^{1)}$	[-]	1.67							
Characteristic resistance Steel 5.8	$M_{Rk,s}^0$	[Nm]	7.6	19		37	37	65	166	324
Partial safety factor	$\gamma_{Ms}^{1)}$	[-]	1.25							
Characteristic resistance Steel 8.8	$M_{Rk,s}^0$	[Nm]	12	30		59	60	105	266	519
Partial safety factor	$\gamma_{Ms}^{1)}$	[-]	1.25							
Steel failure with lever arm, Stainless steel A4, HCR										
Characteristic resistance (Threaded rod: property class 70)	$M_{Rk,s}^0$	[Nm]	11	26	–	52	92	233	454	
Partial safety factor	$\gamma_{Ms}^{1)}$	[-]	1.56							
Characteristic resistance (Threaded rod: property class 80)	$M_{Rk,s}^0$	[Nm]	12	30	–	60	105	266	519	
Partial safety factor	$\gamma_{Ms}^{1)}$	[-]	1.33							
Concrete pryout failure, Steel zinc plated										
Factor in eq. (5.6) ETAG Annex C, 5.2.3.3	k	[-]	1.0				1.5		2.0	
Partial safety factor	$\gamma_{Mcp}^{1) 2)}$	[-]	1.5							
Concrete pryout failure, Stainless steel A4 / HCR										
Factor in eq. (5.6) ETAG Annex C, 5.2.3.3	k	[-]	1.0	1.7	–	1.7		2.0		
Partial safety factor	$\gamma_{Mcp}^{1) 2)}$	[-]	1.5		–	1.5				
Concrete edge failure										
Effective length of anchor under shear loading	l_f	[mm]	30	30	40	30	40	50	65	80
Outside diameter of anchor	d_{nom}	[mm]	8	10	10	12	12	15	20	25
Partial safety factor	$\gamma_{Mc}^{1) 2)}$	[-]	1.5			2	1.5			

¹⁾ In absence of other national regulations²⁾ The partial safety factor γ_2 is included**MKT Drop-in anchor E / ES****Design method A,
Characteristic values for shear loads****Annex 6**of European
technical approval**ETA-02/0020**

Table 7: Displacements under tension loads

Anchor size			M6	M8	M8x40	M10x30	M10	M12 M12x80	M16 M16x80	M20	
Steel zinc plated											
Tension load in non-cracked concrete	N	[kN]	3	3	3.6	3.3	4.8	6.4	10	14.8	
Displacement	δ_{N0}	[mm]					0.24				
	$\delta_{N\infty}$	[mm]					0.36				
Stainless steel A4 / HCR											
Tension load in non-cracked concrete	N	[kN]	4	4	4.3	—	6.1	8.5	12.6	17.2	
Displacement	δ_{N0}	[mm]					0.12				
	$\delta_{N\infty}$	[mm]					0.24				

Table 8: Displacements under shear loads

Anchor size			M6	M8	M8x40	M10x30	M10	M12 M12x80	M16 M16x80	M20
Steel zinc plated										
Shear load in non-cracked concrete	V	[kN]	2	4	4	5.7	4	11.3	18.8	32.2
Displacement	δ_{V0}	[mm]	0.9	0.9	1.0	1.5	0.6	1.2	1.2	1.6
	$\delta_{V\infty}$	[mm]	1.3	1.3	1.5	2.3	0.9	1.9	1.9	2.4
Stainless steel A4 / HCR										
Shear load in non-cracked concrete	V	[kN]	3.5	5.2	5.2	—	6.5	11.5	19.2	30.4
Displacement	δ_{V0}	[mm]	1.9	1.1	0.7	—	1.0	1.7	2.4	2.6
	$\delta_{V\infty}$	[mm]	2.8	1.6	1.0	—	1.5	2.6	3.6	3.8

MKT Drop-in anchor E / ES

Displacements

Annex 7

of European
technical approval

ETA-02/0020

Installation instructions

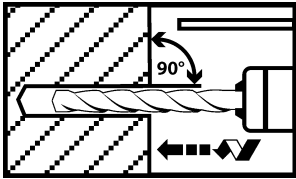

Drill hole perpendicular to concrete surface.

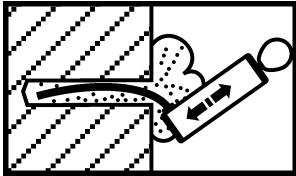

Blow out dust.

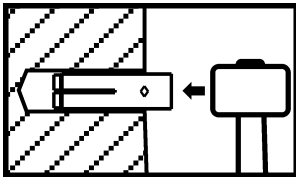

Drive in anchor.

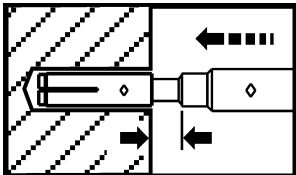

Drive in cone by using setting tool.

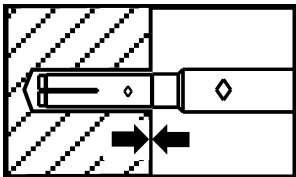

Shoulder of setting tool must fit on anchor rim.

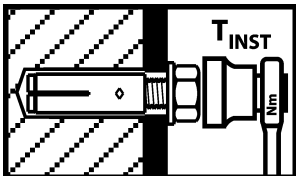

Apply installation torque T_{inst} by using torque wrench.

MKT Drop-in anchor E / ES

Installation instructions

Annex 8

of European
technical approval

ETA-02/0020