

Allgemeine bauaufsichtliche Zulassung

Zulassungsstelle für Bauprodukte und Bauarten

Bautechnisches Prüfamt

Eine vom Bund und den Ländern
gemeinsam getragene Anstalt des öffentlichen Rechts
Mitglied der EOTA, der UEAtc und der WFTAO

Datum:

17/08/2011

Geschäftszeichen:

I 21-1.21.1-66/11

Zulassungsnummer:

Z-21.1-1785

Geltungsdauer

vom: **17 August 2011**

bis: **17 August 2016**

Antragsteller:

MKT

Metall-Kunststoff-Technik GmbH & Co. KG

Auf dem Immel 2
67685 Weilerbach

Zulassungsgegenstand:

MKT Easy zur Verankerung in Spannbeton-Hohldeckenplatten

MKT Easy for anchoring in pre-stressed hollow core concrete slabs

The above-named construction product is hereby granted *allgemeine bauaufsichtliche Zulassung* ('national technical approval').

This *allgemeine bauaufsichtliche Zulassung* ('national technical approval') comprises eight pages und eight annexes. The product is granted the initial technical approval on 17.08.2006.

English translation prepared by DIBt – Original version in German language

DIBt

I GENERAL CONDITIONS

- 1 The *allgemeine bauaufsichtliche Zulassung* ('national technical approval') verifies the usability and applicability of the construction product in accordance with the *Landesbauordnungen* ('building regulations of the German Laenders').
- 2 Where the *allgemeine bauaufsichtliche Zulassung* ('national technical approval') places requirements on the specific expertise and experience of persons entrusted with the manufacture of construction products and construction types in accordance with the regulations of the German Laenders conforming to Article 17 section 5 of the *Musterbauordnung* ('Model Building Code'), it must be ensured that this expertise and experience can also be proven via equivalent verification of other member states of the European Union. This shall also apply, where relevant, for equivalent verification submitted in accordance with the agreement on the European Economic Area (EEA) or other bilateral agreements.
- 3 The *allgemeine bauaufsichtliche Zulassung* ('national technical approval') does not replace the legally prescribed authorisations, approvals and certifications for carrying out construction projects.
- 4 The *allgemeine bauaufsichtliche Zulassung* ('national technical approval') is granted without prejudice to the rights of third parties, particularly private intellectual property rights.
- 5 Manufacturers and distributors for the construction project must, without prejudice to additional regulations in the "Special conditions", provide the user of the construction product with copies of the *allgemeine bauaufsichtliche Zulassung* ('national technical approval') and indicate that this *allgemeine bauaufsichtliche Zulassung* ('national technical approval') must be present at the site of use. The public authorities concerned must be provided with copies of the *allgemeine bauaufsichtliche Zulassung* ('national technical approval') upon request.
- 6 The *allgemeine bauaufsichtliche Zulassung* ('national technical approval') may only be duplicated in its entirety. Publication of extracts requires the approval of the Deutsches Institut für Bautechnik. Text and drawings in advertising materials shall not contradict the *allgemeine bauaufsichtliche Zulassung* ('national technical approval'). Translations of the *allgemeine bauaufsichtliche Zulassung* ('national technical approval') must contain the note "This translation of the German original document has not been verified by the Deutsches Institut für Bautechnik".
- 7 The *allgemeine bauaufsichtliche Zulassung* ('national technical approval') may be withdrawn. The provisions of the *allgemeine bauaufsichtliche Zulassung* ('national technical approval') can be subsequently supplemented and amended, particularly where this is necessitated by new technical findings.

II SPECIAL CONDITIONS

1 Construction product and area of application

1.1 Construction product

The MKT Easy is a torque-controlled expansion anchor made of galvanised steel. It consists of an expansion sleeve and a cone with internal thread and a hexagon bolt with washer or a threaded rod with washer and hexagon nut.

Turning the bolt or threaded rod separates the cone from the expansion sleeve. By applying the installation torque, the cone is pulled into the expansion sleeve and expands it.

Annex 1 illustrates the anchor when installed.

1.2 Area of application

The anchor may only be used for anchorage with primarily static loads in pre-stressed hollow core concrete slabs ceilings that have received *allgemeine bauaufsichtliche Zulassung* ('national technical approval') and are made from normal weight concrete of a strength class of at least C45/55 in accordance with DIN EN 206-1 or B 55 pursuant to DIN 1045:1988-07.

The hollow-wall anchor may only be fastened in pre-stressed hollow core concrete slabs ceilings with a hollow space width that does not exceed 4.2 times the web width (see drawing in Annex 1).

The anchor may be used as a multiple use application for fastening light ceiling coverings and joist constructions in accordance with DIN 13964:2007-02 in pre-stressed hollow core concrete ceilings and for statically comparable anchoring up to 1.0 kN/m². Components shall be affixed such that, in the event of failure of a fastening point, load transfer to two adjacent fastening points is possible. A fastening point is a fastening that can consist of one or more anchors.

Where fire resistance duration requirements apply, the conditions in section 3.2.9 must be observed.

The anchor of galvanised steel may only be used in structures in closed rooms, e.g. apartments, offices, schools, hospitals and sales rooms, with the exception of humid rooms.

2 Conditions for the construction product

2.1 Properties and composition

The anchor dimensions and material values shall correspond to the specifications shown in the annexes in its dimensions and material values.

The material values, dimensions and tolerances of the anchor not specified in this *allgemeine bauaufsichtliche Zulassung* ('national technical approval') shall correspond to the specifications submitted to the Deutsches Institut für Bautechnik, certification body and external monitoring body.

The anchor consists of a non-flammable material of Class A in accordance with DIN 4102-1:1998-05 "Fire behaviour of building materials and building components: Building materials; Concepts, requirements and tests".

The thread parts shall correspond to the strength classes in accordance with DIN EN ISO 898-1 specified in Annex 2.

2.2 Labelling

The packaging, enclosed instruction sheet or delivery note for the anchor shall be marked by the manufacturer with a conformity mark (Ü-marking) in accordance with the conformity mark ordinance of the federal states. The identifying mark of manufacturing plant, approval number and complete trade name of the anchor shall also be indicated. Labelling may only take place if the requirements of section 2.3 are fulfilled.

Each anchor must be stamped with the identifying mark of the manufacturer, anchor type and thread diameter in accordance with Annex 2.

2.3 Certificate of conformity

2.3.1 General

Conformity of the anchor with the conditions of this *allgemeine bauaufsichtliche Zulassung* ('national technical approval') must be confirmed for each manufacturing plant with a certificate of conformity based on factory production control and regular external monitoring including an initial test of the anchor in accordance with the following conditions.

The anchor manufacturer must engage a recognised certification body and recognised monitoring body for the granting of the certificate of conformity and the external monitoring, including the product testing.

The statement, that the conformity certification is issued, the manufacturer has to specify by labelling the products with the conformity mark (Ü-marking) with the hint of the intended use.

The certification body shall provide the Deutsches Institut für Bautechnik with a copy of the certificate of conformity it has granted for its record.

2.3.2 Factory production control

Factory production control must be set up and implemented in each manufacturing plant. Factory production control includes continual monitoring to be undertaken by the manufacturer in order to ensure that the construction products it manufactures correspond to the conditions of this *allgemeine bauaufsichtliche Zulassung* ('national technical approval').

The requirements submitted to the Deutsche Institut für Bautechnik and external monitoring body for the scope, nature and frequency of the production control shall apply.

The results of the factory production control should be recorded and evaluated. The records shall contain at least the following information:

- Description of the construction product or base material and its components
- Nature of the control or test
- Date of manufacture and testing of the construction product or base material or components
- Results of the control or testing and, where relevant, comparison with the requirements
- Signature of the person responsible for factory production control.

The records shall be stored for at least five years and submitted to the monitoring body responsible for external monitoring. These shall also be submitted to the Deutsches Institut für Bautechnik and the responsible *oberste Bauaufsichtsbehörde* ('highest construction supervision authority') upon demand.

Where test results are unsatisfactory, the manufacturer must immediately take the necessary measures to rectify the defect. Construction products that do not correspond to requirements should be handled in such a way that prevents confusion with conforming products. Once the defect is rectified, the relevant test should be immediately repeated provided that this is technically possible in order to prove that the defect has been rectified.

2.3.3 External monitoring

Factory production control in each manufacturing plant shall be inspected regularly, at least twice per year, via external monitoring.

As part of the external monitoring, an initial test should be undertaken and samples taken. The sampling and testing is the responsibility of the recognised monitoring body.

The requirements submitted to the Deutsches Institut für Bautechnik and external monitoring body for the scope, nature and frequency of the external monitoring shall apply.

The results of the certification and external monitoring must be retained for at least five years. These must also be submitted by the certification body or monitoring body to the Deutsches Institut für Bautechnik and the responsible *oberste Bauaufsichtsbehörde* ('highest construction supervision authority') upon demand.

3 Conditions for design and dimensioning

3.1 Design

The fastenings should be designed in line with standard engineering practice. Verifiable calculations and structural diagrams should be prepared with regard to the loads to be anchored.

Commercial standard hexagon screw or threaded rods and hexagon nuts may be used if the following requirements are fulfilled:

- material, dimensions and mechanical properties are according to Annex 2
- confirmation of material and mechanical properties by inspection certificate 3.1 according to EN 10204:2005, the documents shall be retained

If the hexagon screw or threaded rod is not delivered by the manufacturer of the anchor, the designing engineer shall define it regarding the length depending on thickness of fixture, minimum screwing depth and possible tolerances according to Annex 3.

3.2 Dimensioning

3.2.1 General

The fastenings should be dimensioned in line with standard engineering practice. It shall be demonstrated that the hollow space width of the pre-stressed hollow core concrete slabs ceilings does not exceed 4.2 times the web width ($b_H \leq 4.2 b_{St}$) cf. Annex 1. Proof of direct local introduction of force into the concrete is provided. Transfer of the loads to be anchored in the component must be demonstrated.

Bending stress of the anchor does not need to be unconsidered if all of the following conditions are observed:

- The component to be connected shall consist of metal and shall be clamped completely against the concrete without an intermediate layer in the area of the fastening.
- The fixture shall be in contact with bolt or rod over its entire thickness.
- The diameter of the clearance hole in the fixture may not exceed the values in Annex 3.

If the specified diameter of the clearance hole in the fixture cannot be adhered to, special measures must be taken (e.g. reinforced washers) due to the risk of pulling through. Additional stresses that may arise in the anchor, the component to be connected or the component to which the anchor is fastened due to hindered deformation (e.g. during temperature changes) should be taken into account.

3.2.2 Admissible loads

The admissible load for the anchor for fastening in pre-stressed hollow core concrete slabs ceilings apply for the load directions of tension, shear and inclined load at every angle. The admissible loads are specified depending on the bottom flange thickness d_u of the pre-stressed concrete hollow ceiling slabs in Annex 5.

3.2.3 Anchor properties and component dimensions

The spacing and edge distances necessary for utilisation of the admissible load and component dimensions (bottom flange thickness d_u) are specified in Annex 5, Table 4. See Annex 3 for definitions of dimensions.

3.2.4 Double anchor groups

Double anchor groups consist of 2 anchors with spacing smaller than s_{cr} in accordance with Annex 5. The minimum spacing s_{min} according Annex 5, Table 4 shall always be observed. The relevant admissible loads apply for the double anchor group. The admissible load for the anchor with the greatest load may not exceed the values specified for single anchors.

For anchors with spacing $s_{min} \leq s \leq s_{cr}$, the admissible load may be linearly interpolated, whereby twice the admissible load for single anchors may be applied for the double anchor group with uniformly applied load introduction for the limit value $s = s_{cr}$.

The anchors are configured in accordance with Annex 3 and 7.

3.2.5 Bending stress

The admissible bending moment of the anchor is specified in Annex 3. The theoretical fixing point is displaced by the distance of the thread diameter measurement behind the surface of the concrete.

When bending under additional tension, the tensile load component in place shall not exceed the following value:

$$F_z \leq \text{adm. } F (1 - M/\text{adm. } M)$$

adm. F = admissible load according to Annex 5

adm. M = admissible bending moment according to Annex 3

F_z = applied tensile load component

M = existing bending moment.

3.2.6 Displacement behaviour

Under tensile loading equivalent to the admissible loads according to Annex 5, displacements of 0.1 mm are to be expected for anchor sizes M6 and M8 and up to 0.4 mm for anchor sizes M10 and M12. Under continuous loading, increased the displacement should be expected.

Under shear load equivalent to the admissible loads according to Annex 5, displacements up to 0.9 mm are to be expected for anchor sizes M6 and M8 and up to 1.4 mm for anchor sizes M10 and M12. The existing hole clearance between the anchor and fixture should also be taken into account. The displacement under inclined load can be calculated from the displacements caused by the partial tension and shear loads. The displacements are calculated from the specified reference values via linear interpolation.

3.2.7 Concrete member load-bearing capacity

The shear loading capacity of the pre-stressed hollow core concrete slabs ceilings shall be reduced when introducing external loads via anchors in accordance with Annex 6.

If the anchor is used for the attachment of light ceiling coverings and joist constructions in accordance with DIN 13964:2007-02, this reduction is not necessary when proving the shear loading capacity of the pre-stressed hollow core concrete slabs ceilings.

3.2.8 Fire protection

Where fire resistance duration requirements apply, the admissible loads for the fire resistance duration of the individual anchor sizes in accordance with Annex 8 must be observed.

Where fire resistance duration requirements apply, the fixing bolt or threaded rod with washer and hexagon nut for anchor size M6 shall correspond to at least strength class 8.8 in accordance with EN ISO 898-1 and the fixing bolt or threaded rod with washer and hexagon nut for anchor sizes M8 to M12 shall, under fire load, correspond to at least strength class 5.8 in accordance with EN ISO 898-1.

4 Conditions for implementation

4.1 General

The anchor to be fastened should be installed in accordance with the construction drawings prepared pursuant to section 3.1 and the installation instructions of the manufacturer. Before installation of the anchor, the precise location of the prestressed strands should be established using an appropriate metal detection device and marked on the underside of the ceiling. If the anchor is not installed centrally in the hollow-space axis, the distance between the anchor axis and the axis of the prestressed strands shall be at least 50 mm (cf. Annex 7)

4.2 Producing drilled holes

The drilled hole should be produced at a right angle to the surface of the anchorage ground using a carbide impact or hammer drill bit. The carbide drill bits must comply with the specifications of the information leaflet "*Kennwerte, Anforderungen und Prüfungen von Mauerbohrern mit Schneidköpfen aus Hartmetall, die zur Herstellung der Bohrlöcher von Dübelverankerungen verwendet werden*" ('Characteristics, requirements and tests of drill bits with carbide cutting bodies used for producing drilled holes for anchorings') in its version of January 2002. Adherence to the drill bit characteristics must be proven in accordance with section 5 of the information leaflet. Nominal drill-bit diameters and cutting diameters shall correspond to the values set out in Annex 3.

4.3 Installation of anchors

Before installing the anchor, the bottom flange thickness should be checked at the application point.

The anchor can also be installed, observing the distances to pre-stressed strands (Annex 7), in solid material (web) or with bottom flange thickness of > 50 mm. When using bolts, the maximum bolt lengths shall be observed in accordance with Table 3.

The anchor should be introduced into the hole so that the expansion sleeve finishes flush with the concrete surface.

The anchor should be installed with a calibrated torque wrench. The torque moments are specified in Annex 3 and must be applied to the hexagon nut on the threaded rod or hexagon bolt. The anchor is only properly fastened and may only be loaded when the required torque is applied.

Installed anchors can be tested at any time, by re-applying the required installation torque.

4.4 Controlling the installation

When installing anchors, either the contractor entrusted with the installation of the anchors, the construction manager appointed by the contractor or an expert representative of the construction manager must be present on the construction site. This person should ensure proper implementation of the work.

While installing anchors, records of the onsite concrete strength class and the proper assembly of the anchors should be taken by the construction manager or his/her representative. These records shall be present at the construction site throughout the construction project and should be presented to those responsible for controlling upon request. Like the delivery notes, these shall also be retained by the contractor for 5 years after completion of the work.

Andreas Kummerow
Referatsleiter

Beglaubigt
Lange

EASY Hollow Core Anchor for fastening in pre-stressed hollow core concrete slabs ceilings, with a hollow space width that does not exceed 4.2 times the web width ($b_H \leq 4.2b_{St}$)

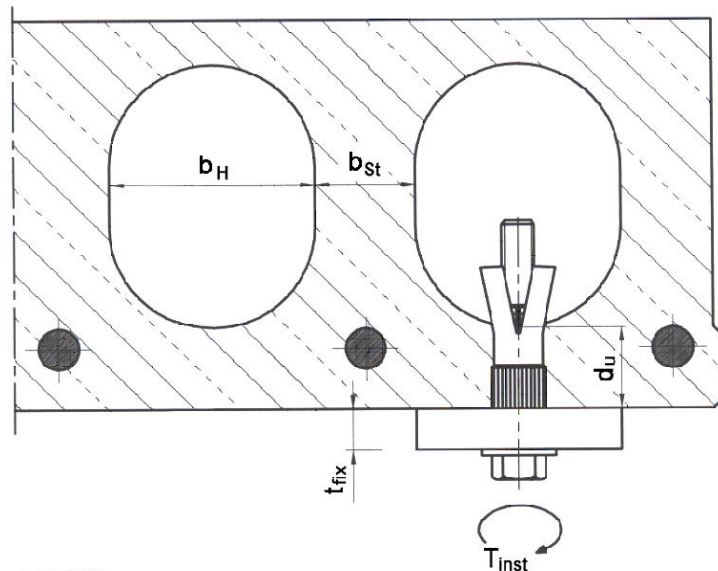
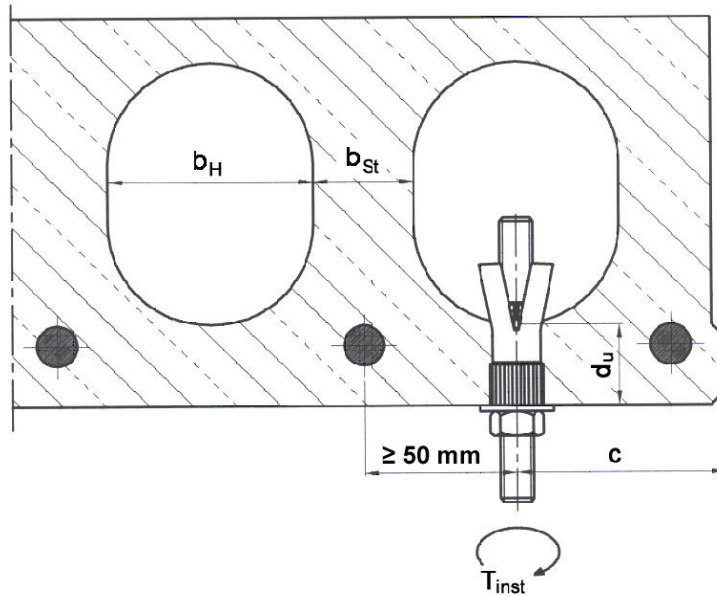

- Legend:
- t_{fix} = thickness of fixture
 - d_u = bottom flange thickness
 - b_H = hollow space width
 - b_{St} = web width
 - c = edge distance
 - T_{inst} = installation torque

MKT EASY

Product and area of application

Annex 1

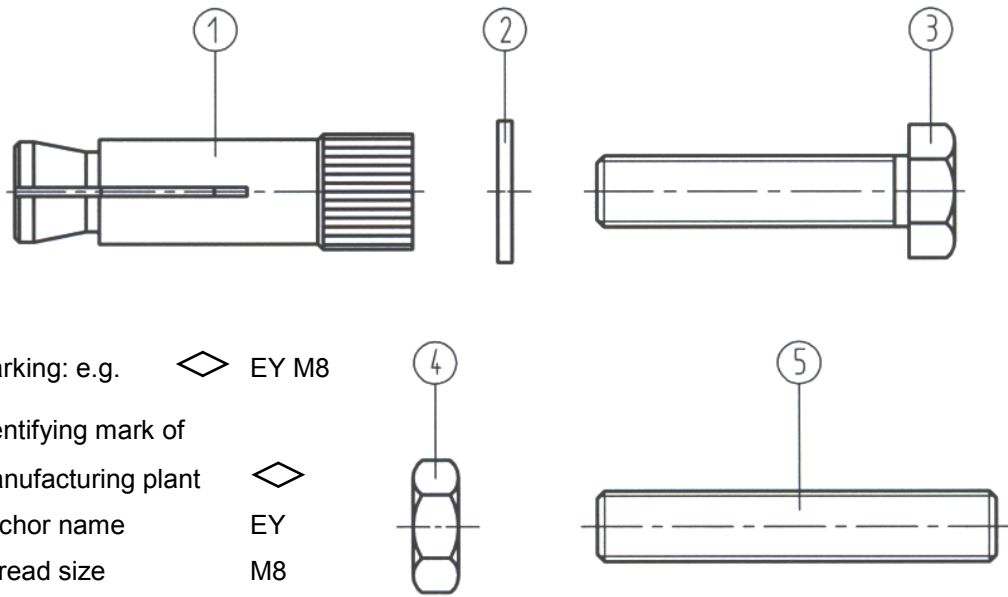
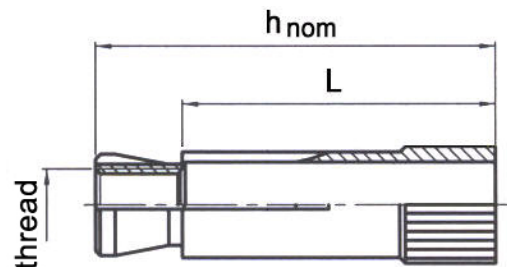

Table 1: Material properties

Part	Description	Steel, zinc plated in accordance with DIN EN ISO 4042 $\geq 5\mu\text{m}$
1	EASY anchor	Steel according to DIN EN 10087, galvanised
2	Washer	Steel, galvanised
3	Hexagon bolt	M6: Property class 8.8 acc. to DIN EN ISO 898-1 M8 – M12: Property class ≥ 5.8 acc. to DIN EN ISO 898-1
4	Hexagon nut	M6: Property class 8 acc. to DIN EN 20898-2 M8 – M12: Property class ≥ 5 acc. to DIN EN 20898-2
5	Threaded rod	M6: Property class 8.8 acc. to DIN EN ISO 898-1 M8 – M12: Property class ≥ 5.8 acc. to DIN EN ISO 898-1

Table 2: Dimensions

Anchor size	Thread	h_{nom} [mm]	L [mm]
M6	M6	40	30
M8	M8	45	35
M10	M10	53	40
M12	M12	58	45



MKT EASY	Annex 2
Material properties, Dimensions	

Table 3: Installation parameters / admissible bending moments

Anchor size		M6	M8	M10	M12
Nominal drill hole diameter	d_0 [mm]	10	12	16	18
Cutting diameter of drill bit	d_{cut} [mm]	10,45	12,5	16,5	18,5
Depth of drill hole	$h_0 \geq$ [mm]	50	55	60	70
Bolt length (in solid material)	min l_s [mm]	$42 + t_{fix}$	$47 + t_{fix}$	$55 + t_{fix}$	$61 + t_{fix}$
	max l_s [mm]	$50 + t_{fix}$	$55 + t_{fix}$	$60 + t_{fix}$	$70 + t_{fix}$
Threaded rod length	min l_b [mm]	$47 + t_{fix}$	$53 + t_{fix}$	$63 + t_{fix}$	$71 + t_{fix}$
Installation torque	T_{inst} [Nm]	10	20	30	40
Diameter of clearance hole in the fixture	$d_f \leq$ [mm]	7	9	12	14
Admissible bending moment	P.cl. 5.8 ¹⁾ [Nm]	-	10,7	21,4	37,4
	P.cl. 8.8 ¹⁾ [Nm]	4,4	17,1	34,2	59,8

1) Labelling, see Table 1

Bolt length

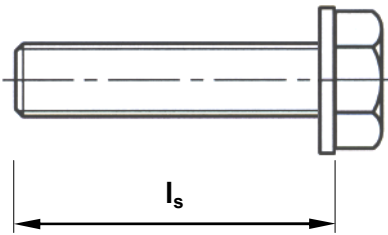

Threaded rod length

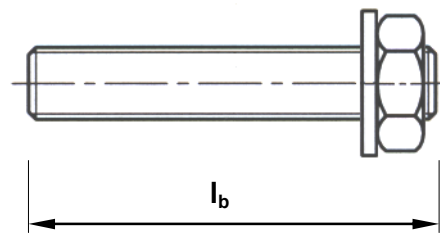

Distances between double anchor groups / single anchors

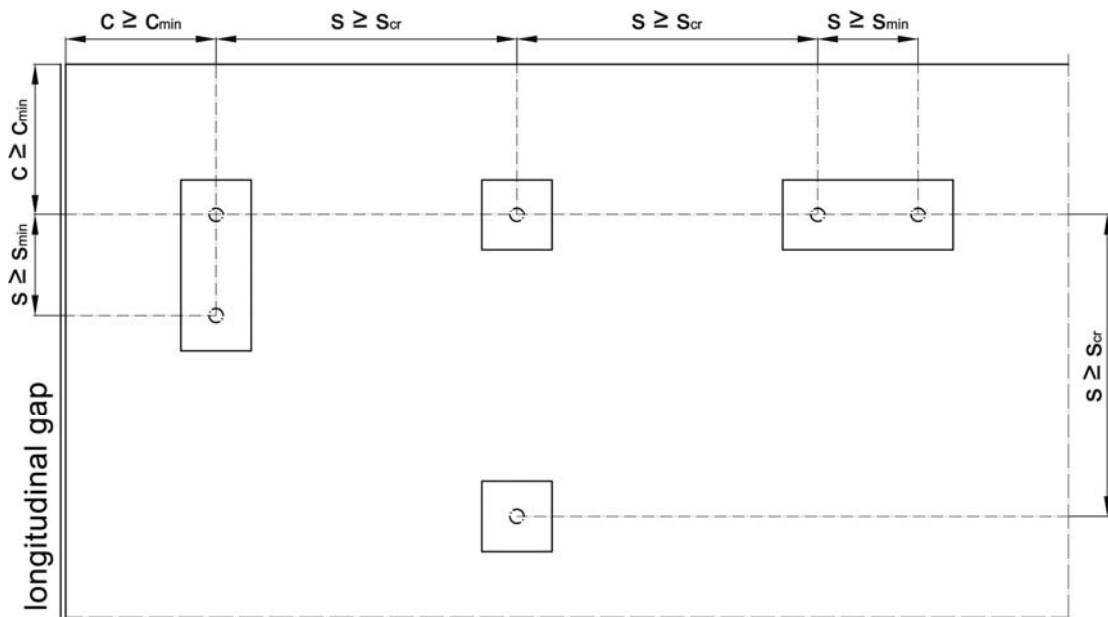

MKT EASY

Installation parameters / Admissible bending moments

Annex 3

Installation instruction

Installation in hollow space

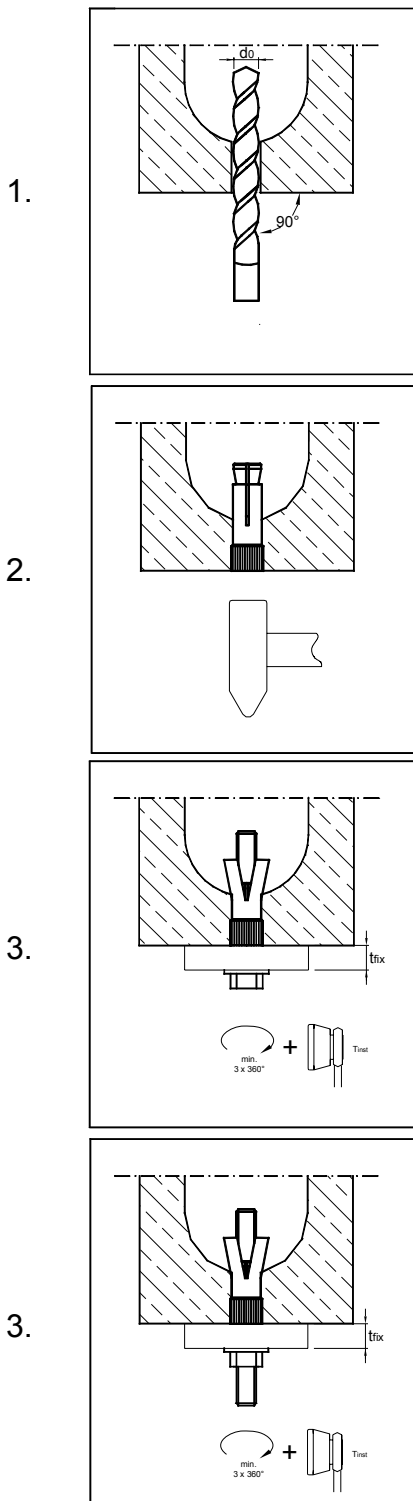

Installation in solid material

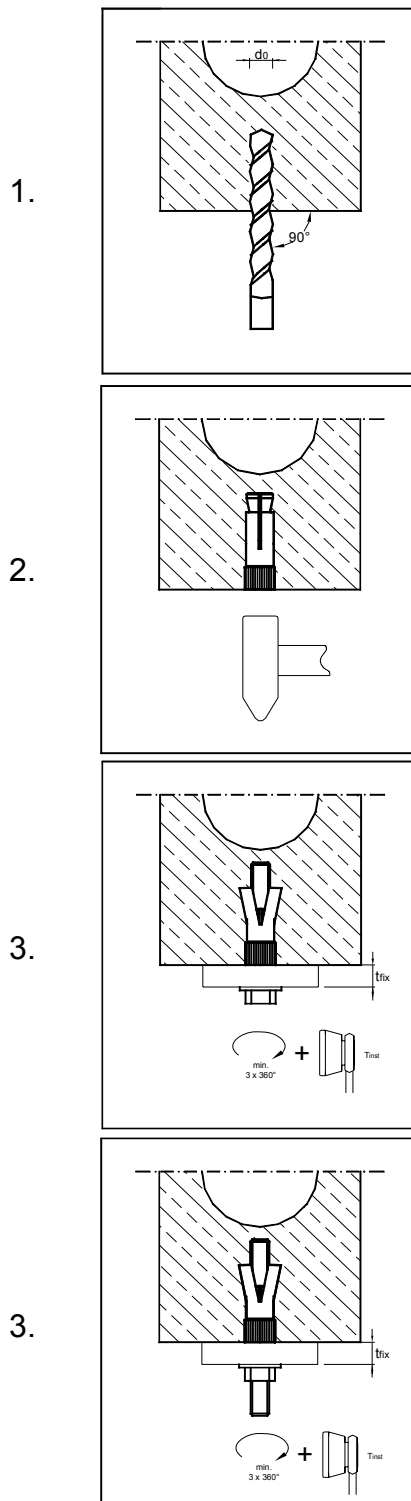

MKT EASY

Installation instruction

Annex 4

Table 4: Admissible loads (adm. F [kN])¹⁾ and anchor distances for tension, shear and inclined loads at every angle in pre-stressed hollow core concrete slabs of strength class \geq C45/55

Size	M6			M8			M10			M12						
	25	30	40	50	25	30	40	50	25	30	40	50				
Bottom flange thickness	$d_u \geq$ [mm]															
Spacing between single anchors or double anchor groups	$s_{cr} \geq$ [mm]															
Single anchors	300															
adm. F ²⁾	0,7	0,9	2,0	2,9	0,7	0,9	2,0	3,6	0,9	1,2	3,0	3,6	1,0	1,2	3,0	4,3
Edge distance	150															
adm. F ²⁾	0,35	0,8	1,8	2,4	0,35	0,8	1,8	3,0	0,8	1,0	2,7	3,0	0,8	1,0	2,7	3,6
Minimum edge distance	100															
Double anchor group ³⁾																
adm. F / Double anchor group ²⁾	0,7	1,4	2,6	3,9	0,7	1,4	2,6	4,8	1,1	2,0	4,8	4,8	1,2	2,0	4,8	5,7
Minimum spacing	150															
Edge distance	150															
Adm. F / Double anchor group ²⁾	0,35	1,25	2,35	3,2	0,35	1,25	2,35	4	0,9	1,8	4,3	4,3	1	1,8	4,3	4,8
Minimum spacing	100															
Edge distance	100															
Minimum edge distance	100															

¹⁾ When introducing external loads via anchors in the pre-stressed hollow core concrete slabs ceilings, the shear load capacity must be reduced in accordance with Annex 6. For fastening light ceiling coverings and joist constructions according to DIN 13964: 2007-02 this reduction is not necessary.

²⁾ For edge distances $c_{min} \leq c \leq c_{cr}$ the admissible loads may be determined via linear interpolation.

³⁾ The admissible loads apply to the double anchor group. The admissible load for the anchor with the highest load may not exceed the values specified for the single anchor.

For double anchor groups with spacing of $s_{min} \leq s \leq s_{cr}$ the admissible load may be linearly interpolated, whereby, when $s = s_{cr}$ for the double anchor group twice the admissible load for single anchors may be applied for the double anchor group with uniformly applied loads for the limit value.

MKT EASY

Admissible loads, Distances

Annex 5

Required reduction in shear load capacity in pre-stressed hollow core concrete slabs ceilings when introducing external loads via the anchors

$$Q_u' = \eta \times Q_u$$

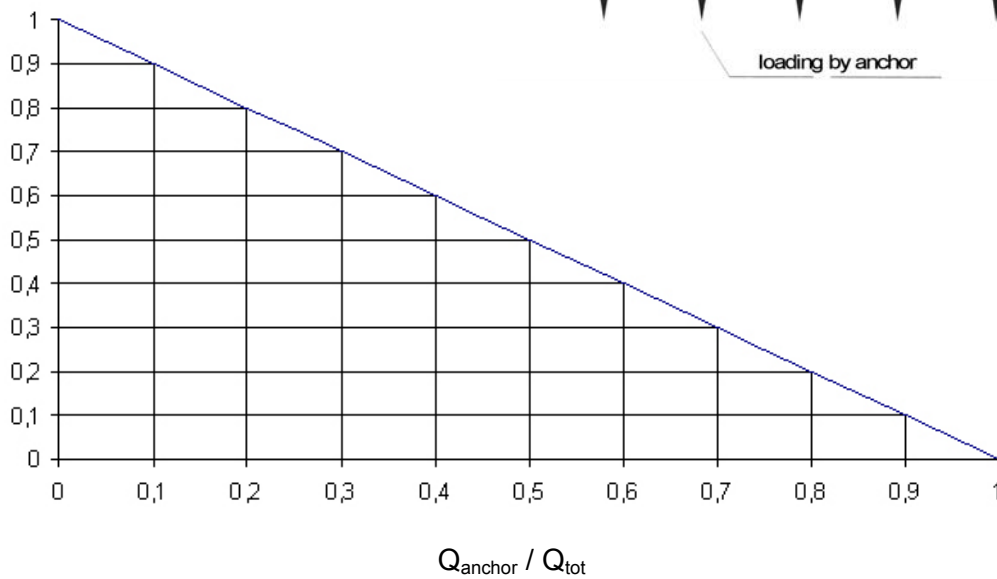
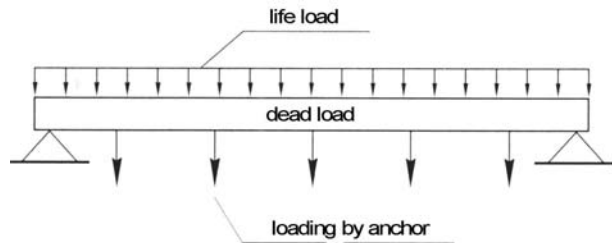

- η = Factor of reduction of shear load capacity Q_u in state of failure.
- Q_{tot} = Shear load from the total loads including the anchor load at the point of design
- Q_{anchor} = Shear load from anchor load at the point of design
- Q_u = Shear load capacity for pre-stressed hollow core concrete slabs ceilings in accordance with the relevant approval.
- Q_u' = Reduced shear load capacity

MKT EASY

Proof of concrete capacity

Annex 6

Admissible location of drilled holes

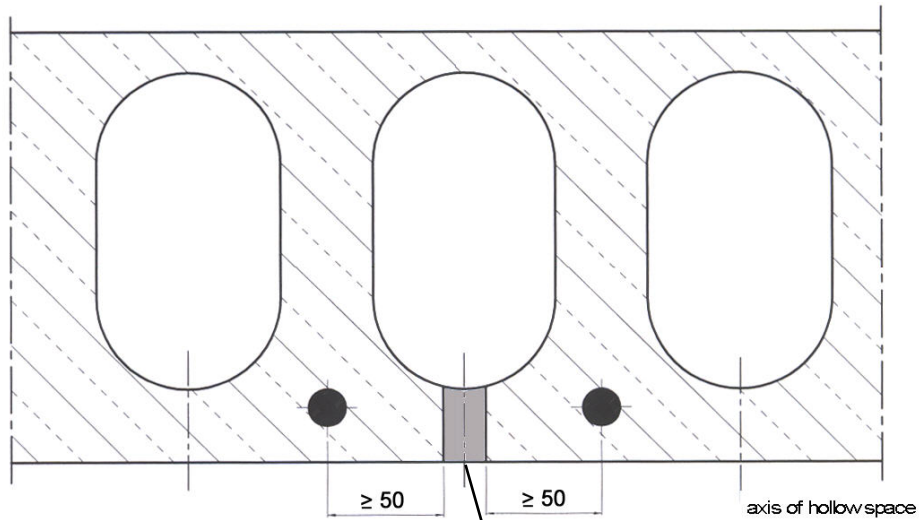

Admissible location of drilled holes

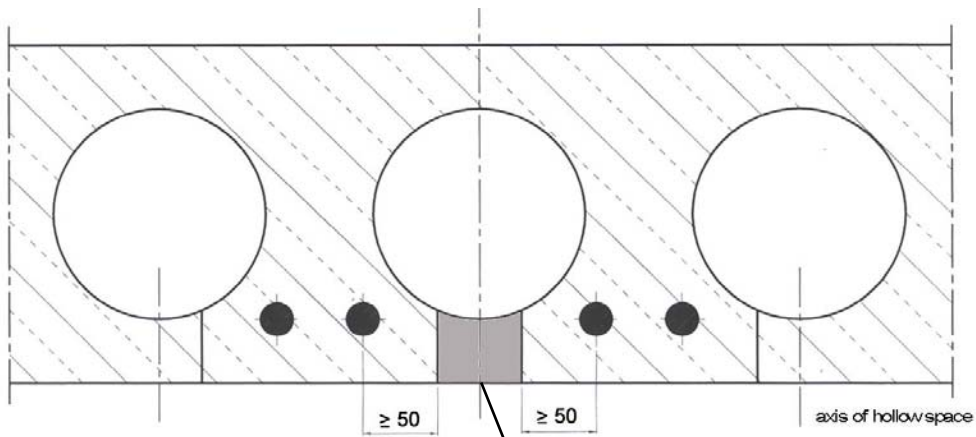

Admissible location of drilled holes

If the anchor is not installed centrally in the hollow-space axis, the distance between the anchor axis and the axis of the pre-stressed strand shall be at least 50 mm, in accordance with the drawing above. The anchor can either be installed into the solid material of the hollow slab or into the hollow slab from above.

MKT EASY

Minimum distance to pre-stressing reinforcement

Annex 7

Admissible loads (adm. F [kN]) under fire exposure for tension, shear and inclined loads at every angle in pre-stressed hollow core concrete slabs of strength class \geq C45/55 or B55

Table 5: Admissible loads for single anchors

Size			M6	M8	M10		M12	
Bottom flange thickness	$d_u \geq$	[mm]	30	30	30	40	30	40
Fire resistance duration [min]	30	adm. F [kN]	0,7	0,9	1,2	1,5	1,2	1,5
	60	adm. F [kN]	0,6	0,9	1,2	1,5	1,2	1,5
	90	adm. F [kN]	0,4	0,7	1,2	1,2	1,2	1,5
	120	adm. F [kN]	0,2	0,4	1,0	1,0	1,2	1,2
Spacing	$s_{cr} \geq$	[mm]	300					
Edge distance	$c_{cr} \geq$ $c_{min} \geq$	[mm]	150					

Table 6: Admissible loads per double anchor group

Size			M6	M8	M10		M12	
Bottom flange thickness	$d_u \geq$	[mm]	30	30	30	40	30	40
Fire resistance duration [min]	30	adm. F [kN]	1,25	1,25	1,8	3,0	1,8	3,0
	60	adm. F [kN]	1,25	1,25	1,8	3,0	1,8	3,0
	90	adm. F [kN]	0,8	1,25	1,8	2,4	1,8	3,0
	120	adm. F [kN]	0,4	0,8	1,8	2,0	1,8	2,4
Spacing and edge distance	The minimum spacing and edge distances in accordance with Table 4, Annex 5 should be adhered to depending upon bottom flange thickness.							

The edge distance shall be \geq 300 mm, if the fire exposure applies from more than one side (applies for Table 5 and 6).

MKT EASY

Admissible loads under fire exposure

Annex 8